

# Visi-Trak<sup>®</sup>

SENSE, MONITOR, CONTROL

ЧЕИЧЕ' МОНИТОР' КОНТРОЛ

## Webinar Quick Reference

- **Joining via telephone** - be sure to enter the Audio PIN noted in your Control Panel. **(A)**
- **Grab Tab** – Click arrow to open/close Control Panel. **(B)**
- **Questions pane (C)** –submit questions and review answers. Broadcast messages to attendees will also show here. **(D)**
  - Type your question and click Send to submit it to the organizer **(E)**
- **Webinar details** – Provided for quick reference **(F)**

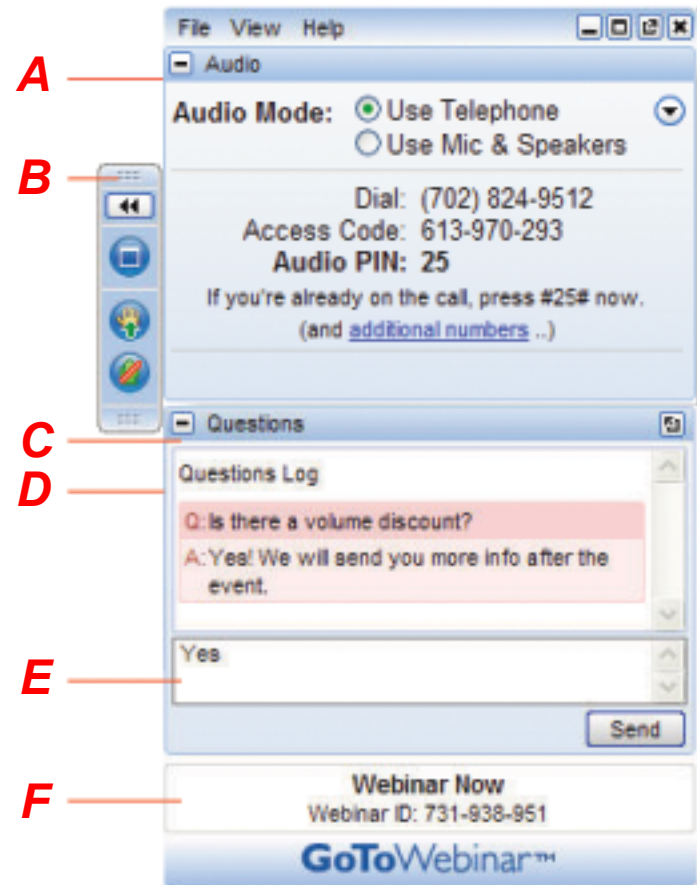



# High Integrity Diecasting

A holistic approach to improved  
die casting quality

Martin Hartlieb

Viami International Inc.

[www.viami.ca](http://www.viami.ca)

November 5, 2013

# Outline

- Aluminum content in automotive - The opportunity for diecasters
- Requirements for High Integrity Aluminum HPDC
- Success factors for high integrity HPDC with technological solutions & case studies
- Alloys and tempers for structural diecastings
- Products and services for you
- Summary and Q & A

# Outline

- **Aluminum content in automotive - The opportunity for diecasters**
- Requirements for High Integrity Aluminum HPDC
- Success factors for high integrity HPDC with technological solutions & case studies
- Alloys and tempers for structural diecastings
- Products and services for you
- Summary and Q & A

## Why Invest in Aluminum Die-casting technologies

- Use of aluminum in automobile components continues to grow significantly
- To reduce weight and improve fuel economy (6.5% *reduction in fuel consumption for 10% reduction in mass*), and reduce emissions
- Political/regulatory, social, and consumer pressures – auto manufacturers are listening.
- HPDC offers many advantages over other processes – if the right technologies and alloys are applied

# Aluminum content in automotive

## The opportunity for diecasters

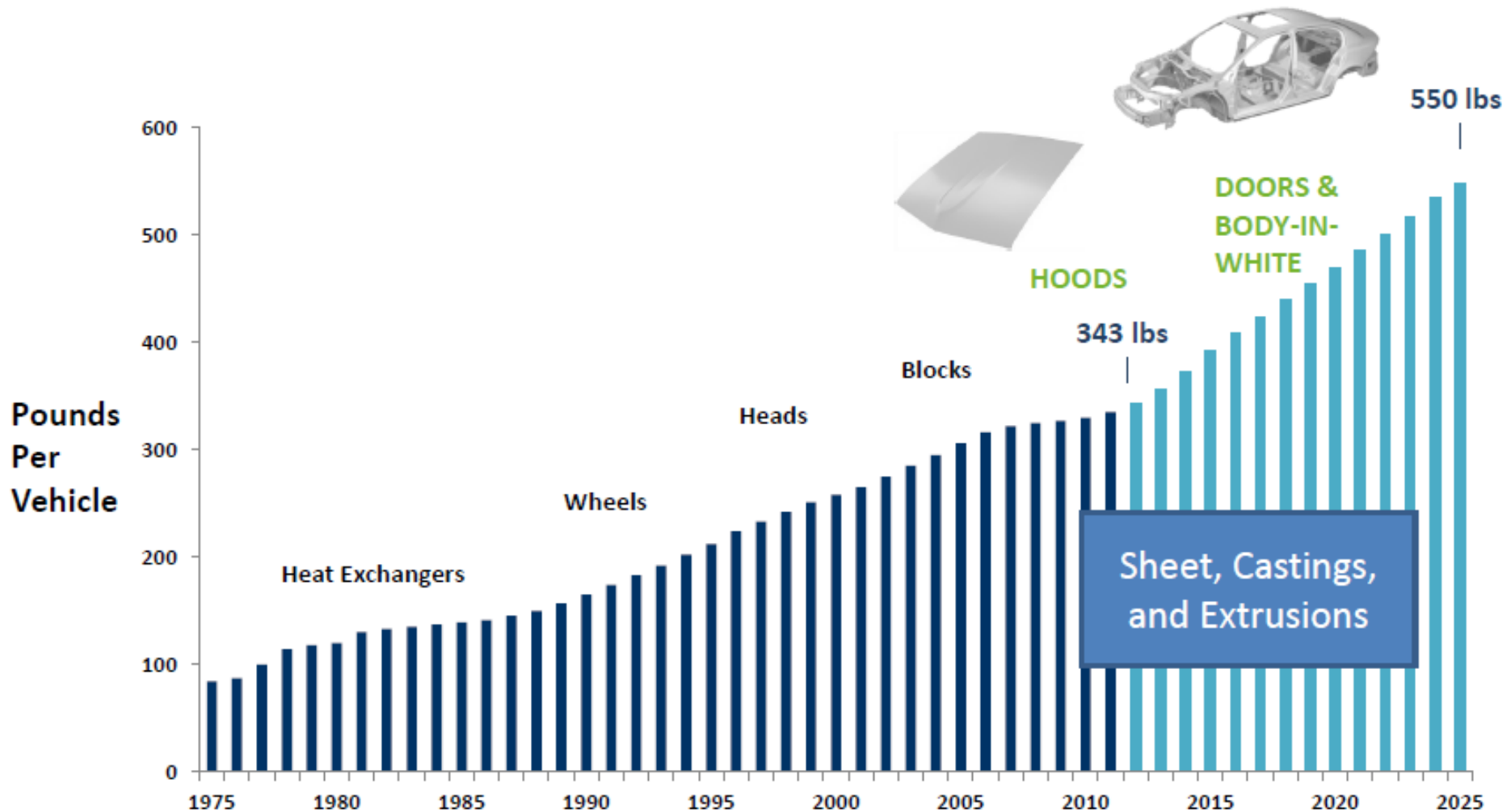

Source: Ducker Worldwide 2011

# Aluminum content in automotive The opportunity for diecasters

**Visi-Trak**<sup>®</sup>  
SENSE, MONITOR, CONTROL

## Most of the HPCD weight is currently in three vehicle systems

*90% of the  
current HPDC  
aluminum use  
is in these  
three systems*

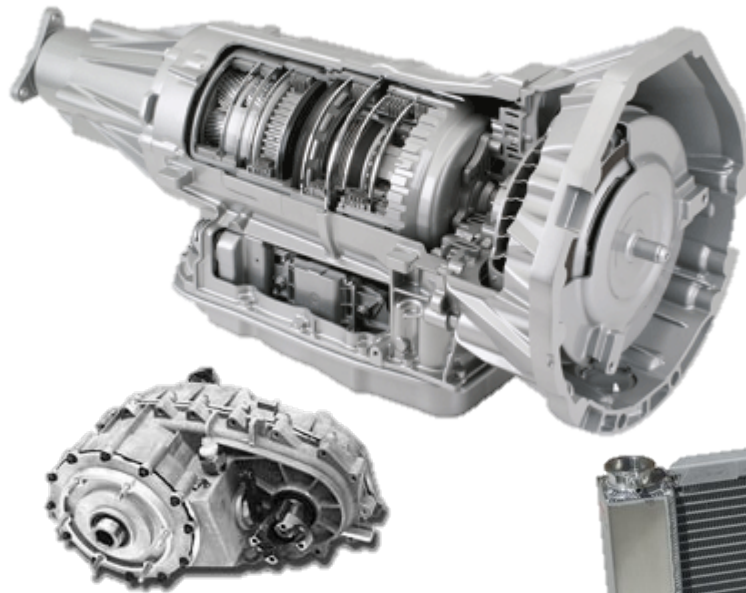

**Transmissions  
and Driveline  
57 lbs. of HPDC**

**Engines  
44 lbs. of HPDC**



**Heat Exchangers  
5 lbs. of HPDC**



*Source: Ducker Worldwide, LLC.*



# Aluminum content in automotive

## The opportunity for diecasters

## 2015 Aluminum Content – growth is mainly in body structure expected!

*The growth of aluminum to 400 pounds by 2015/2016 will depend almost entirely on body and closure growth that is well above normal*

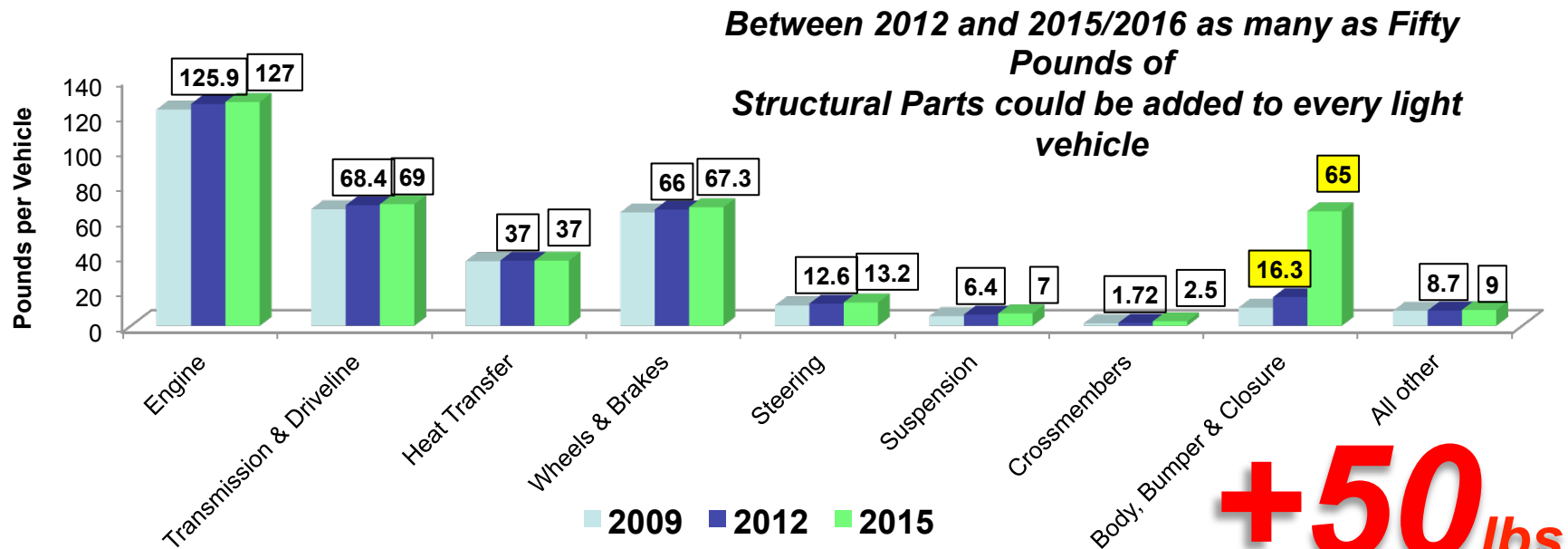

Source: Ducker Worldwide, LLC.

## Aluminum Opportunities – structural diecasting

- New applications like heat-treatable structural aluminum parts will see the largest growth as entire new markets are created.
- Applications are mainly in automotive where lightweighting is becoming a big driver, but also in other industries like motorbikes and recreational vehicles.
- Those parts are higher value added and margin, and offer a clear competitive distinction for die-casters – basically eliminating off-shore competition.
- Already driving substantial growth for European die-casters.

# Aluminum content in automotive The opportunity for diecasters

**Visi-Trak**<sup>®</sup>  
SENSE, MONITOR, CONTROL

## Opportunities for high pressure, high vacuum die cast aluminum body structures

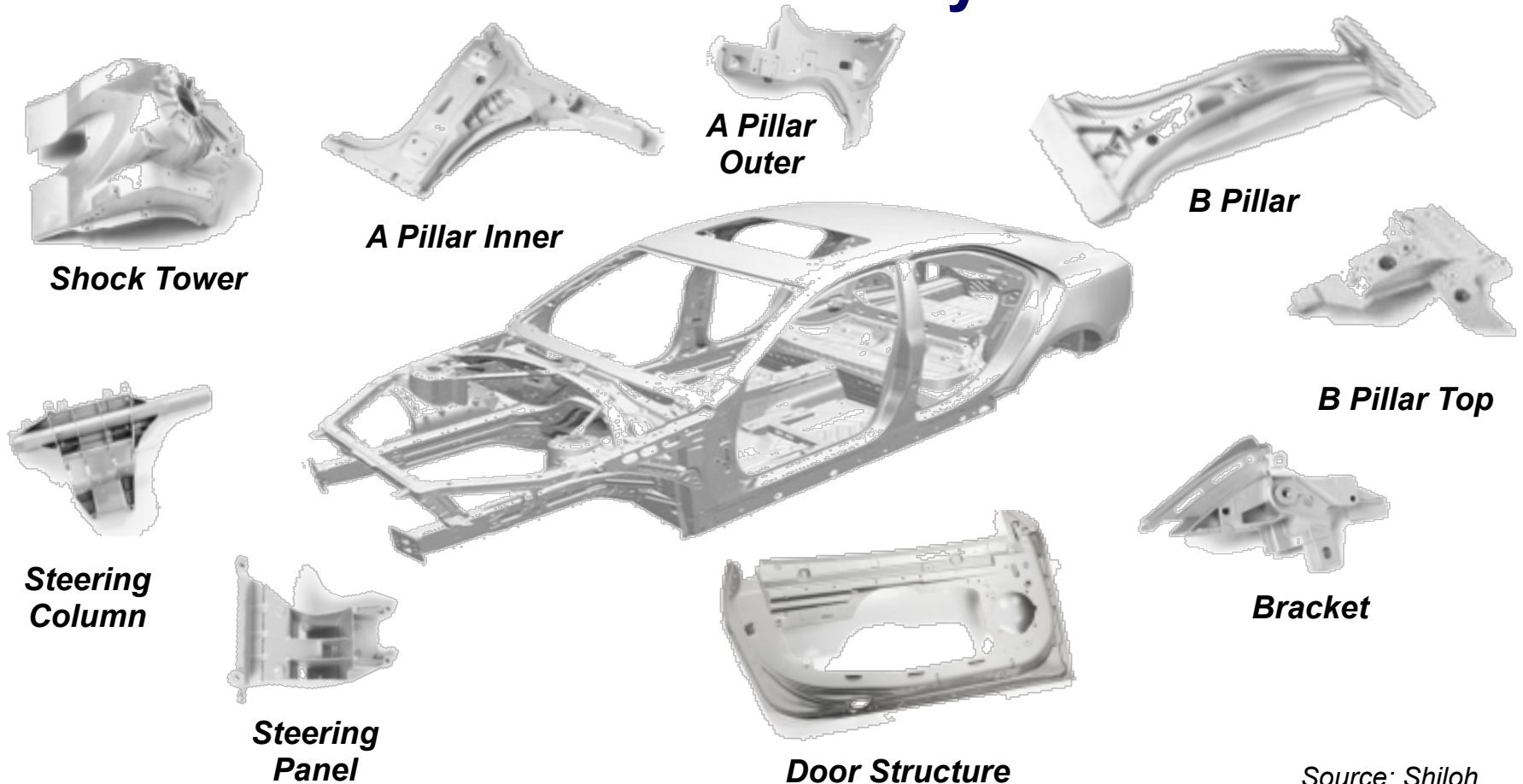

Source: Shiloh

# Aluminum content in automotive

## The opportunity for diecasters

**Visi-Trak**<sup>®</sup>  
SENSE, MONITOR, CONTROL

### Structural aluminum diecastings

are being used for

- Replacing
  - Heavier materials
  - Steel/Al assemblies and stampings
  - Higher cost materials and processes
- Weldments
- Lower weight (thin walls)
  - Increased fuel economy
- Performance increases
- Pressure tight hydraulics
- ...



# Aluminum content in automotive The opportunity for diecasters

## Part integration and weight reduction are drivers

*B pillar 1<sup>st</sup> Audi A8*

**PARTS:** 8  
**WEIGHT:** 4180 g  
9.21 lbs

diecast part

extrusion

sheet

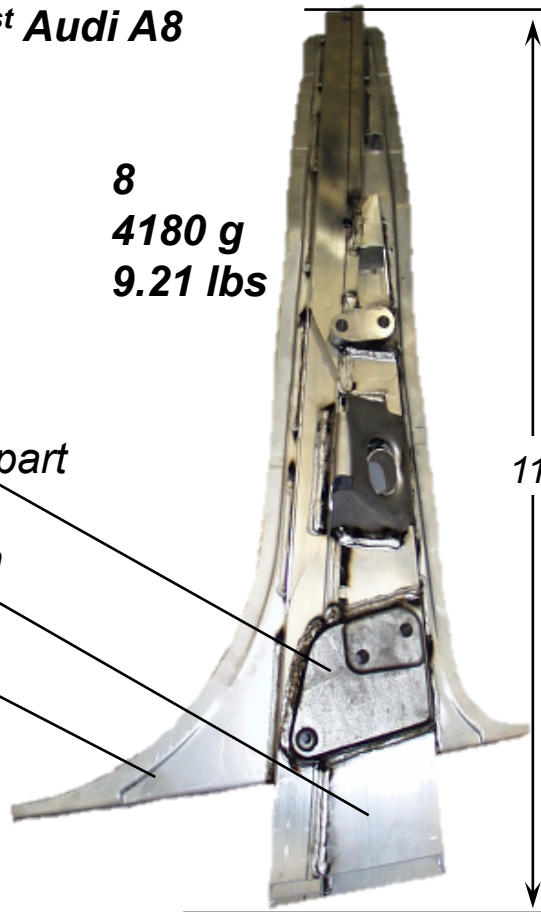

1150

*B pillar Audi A2*

**PARTS:** 1  
**WEIGHT:** 2300 g  
5.07 lbs

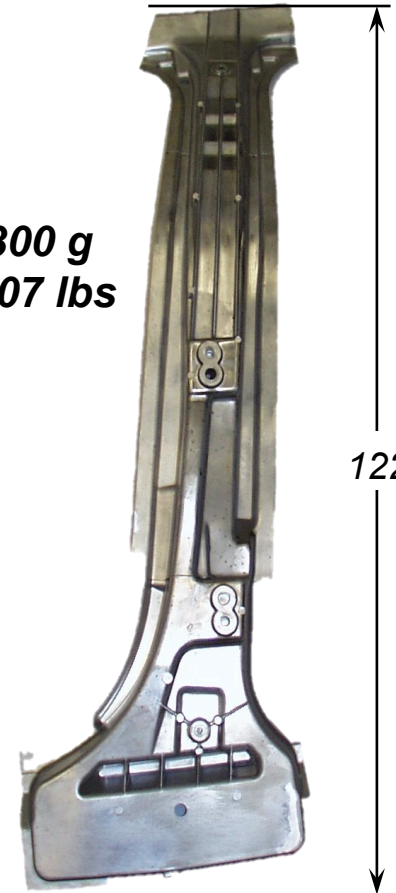
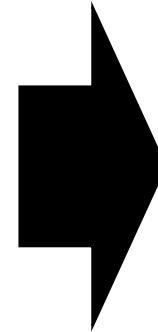

1220

## Part integration and weight reduction are drivers

### BMW X5 shock tower

- Very low level of entrapped gasses allowing for subsequent heat treatment
- BMW part is 40% weight of traditional steel part and comparably priced.
- **High strength and ductility**



*Before: required 5 welded steel stampings weighing 18 lbs.*

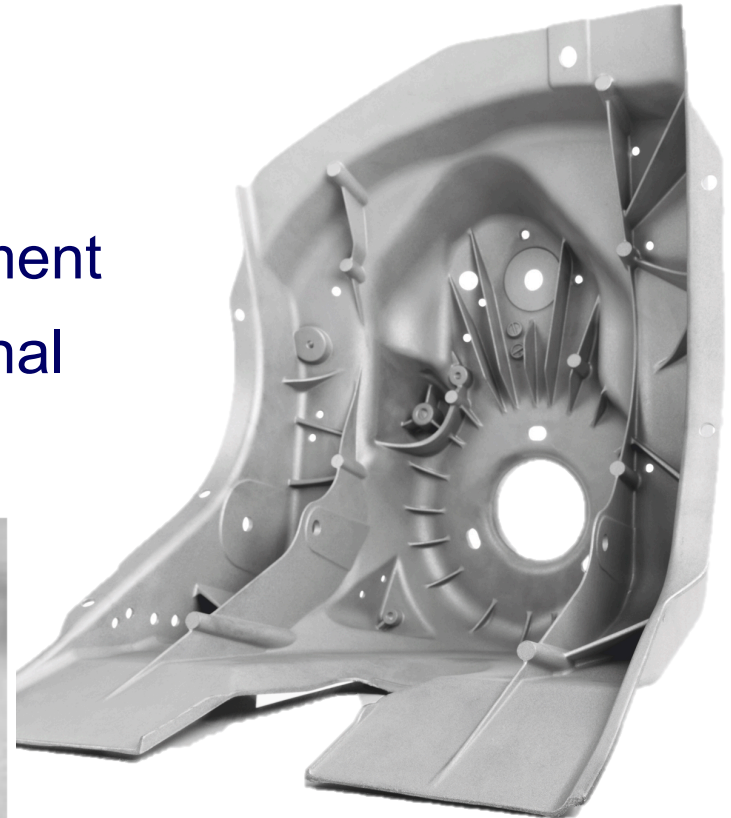

*After: One piece, 7.2 pounds or 40% of traditional steel fender well*

# Aluminum content in automotive

## The opportunity for diecasters

BIW structures: It usually starts in very high-end vehicles before it spreads into high volume cars – example of Mercedes SL

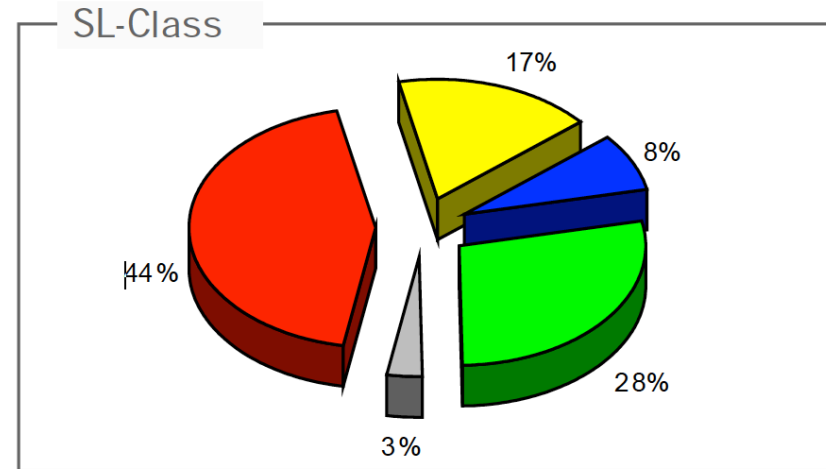
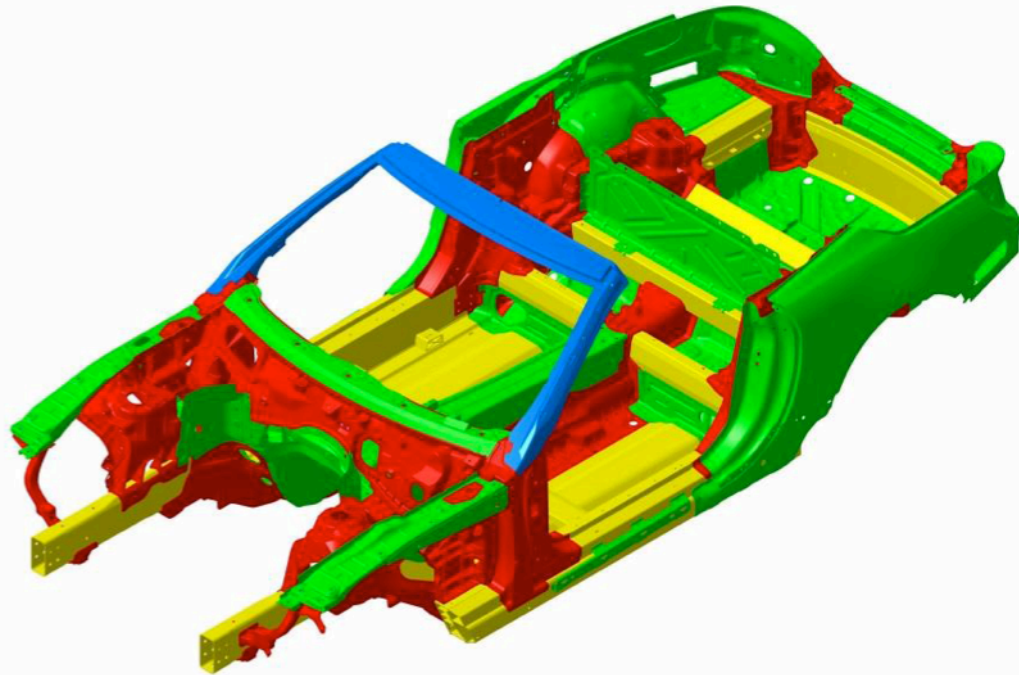

- Cast aluminium
- Aluminium sheet metal
- Others
- Steel
- Aluminium profiles

- *World premiere in January 2012 - Launch March 2012*
- *Aluminium and FRP detachable body components*
- *Weight advantage of approx. 110 kg versus conv. steel design*

Source: Daimler AG, Dr. Lutz Storsberg, Mercedes-Benz Cars, Structural Symposium Bühler AG, Hamilton, Canada, October 1, 2013

# Aluminum content in automotive

## The opportunity for diecasters

**Visi-Trak**<sup>®</sup>  
SENSE, MONITOR, CONTROL

### *BIW structure Mercedes SL*



34 Vacuum-HPDC parts

2 low pressure diecasting parts

Total weight of castings: 110 kg

Source: Daimler AG, Dr. Lutz Storsberg, Mercedes-Benz Cars, Structural Symposium Bühler AG, Hamilton, Canada, October 1, 2013



# Aluminum content in automotive

## The opportunity for diecasters

### Example – Fire wall

#### *BIW structure Mercedes SL*



Dimensions : 356mm,1463mm,  
389mm

weight : 7,0kg

Integrated parts : 6

Optimal for the reaching of  
rigidity goals in a roadster

Source: Daimler AG, Dr. Lutz Storsberg, Mercedes-Benz Cars, Structural Symposium Bühler AG, Hamilton, Canada, October 1, 2013

# Aluminum content in automotive

## The opportunity for diecasters

## Current and potential applications

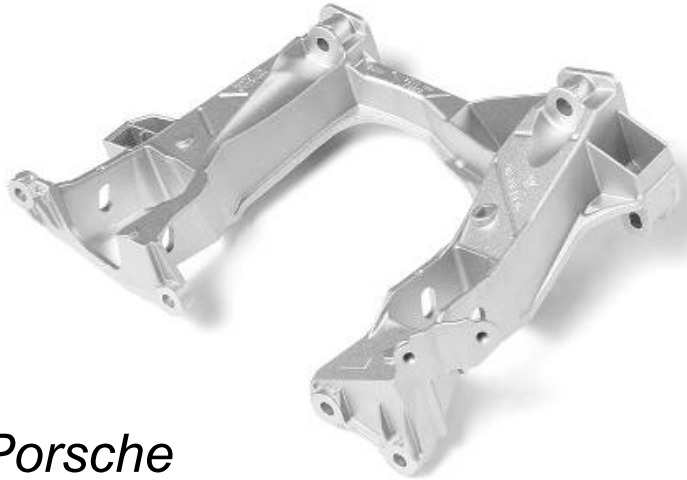

*Porsche  
Side beam member, rear axle*

*Longitudinal Beam*



*Alloy: Aural-3  
Heat Treatment: Auraltherm™*

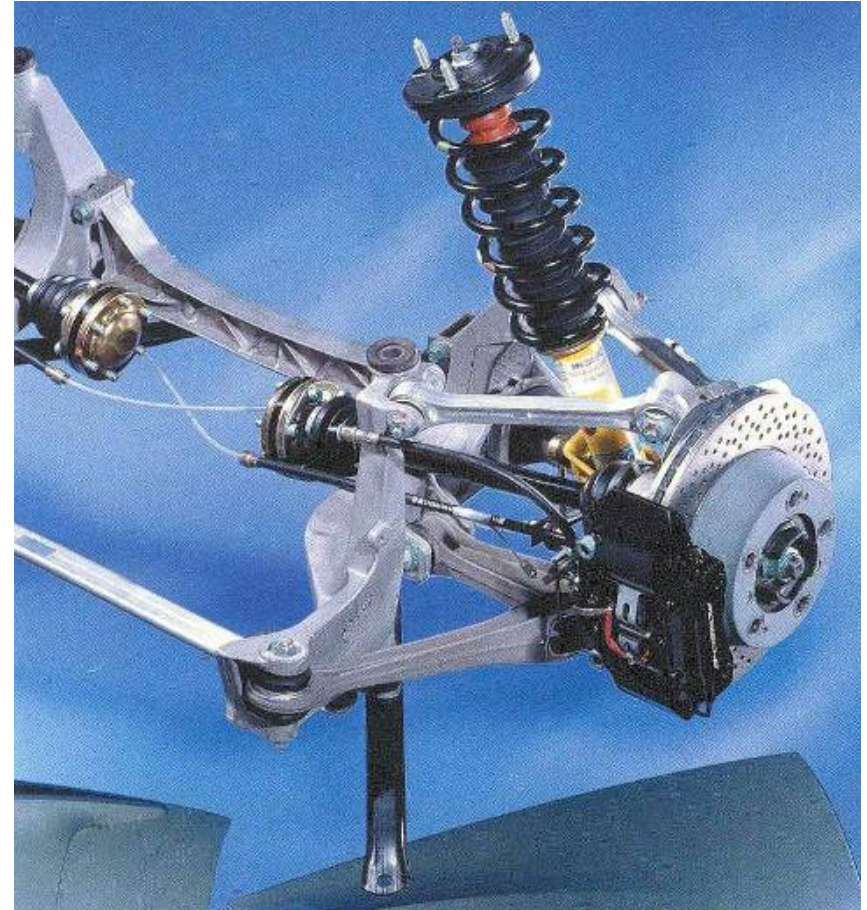

# Aluminum content in automotive

## The opportunity for diecasters

**Visi-Trak**<sup>®</sup>  
SENSE, MONITOR, CONTROL

## Current and potential applications

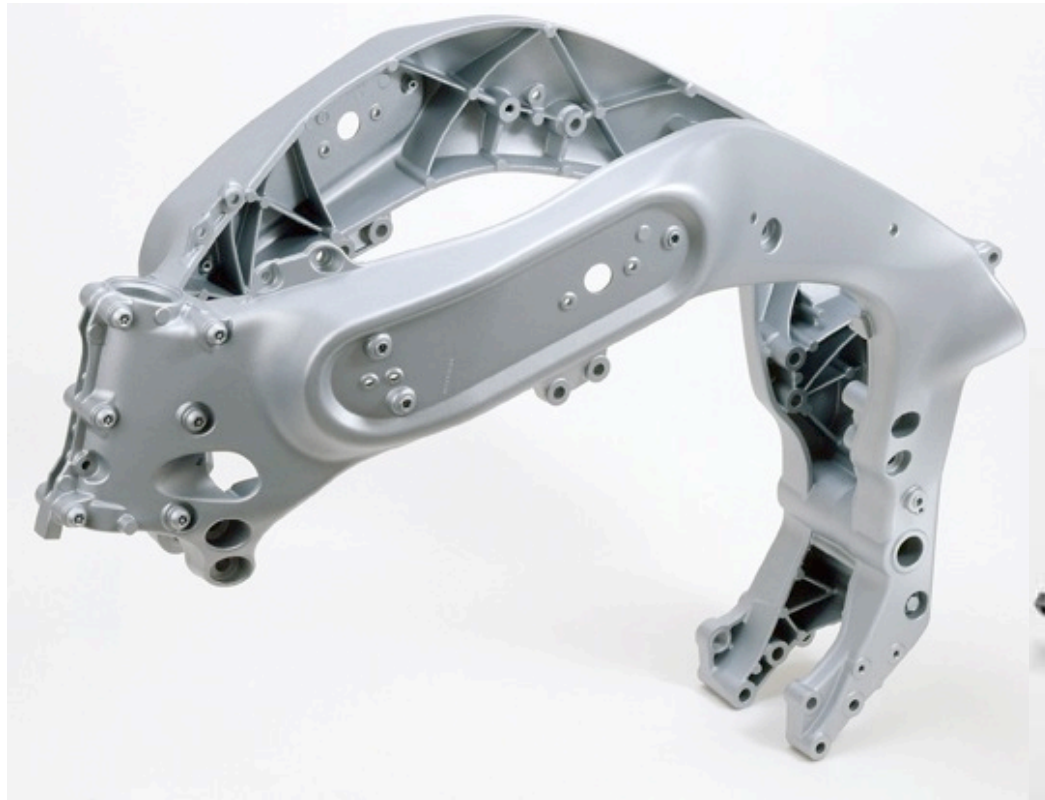

*Yamaha motorbike  
main and seat frame  
in Silafont™ 36 in T5*



## Current and potential applications

- BRP part produced by AMT in Silafont 36 / Aural-2
- replaces two gravity cast parts.
- Significant reduction in machining costs

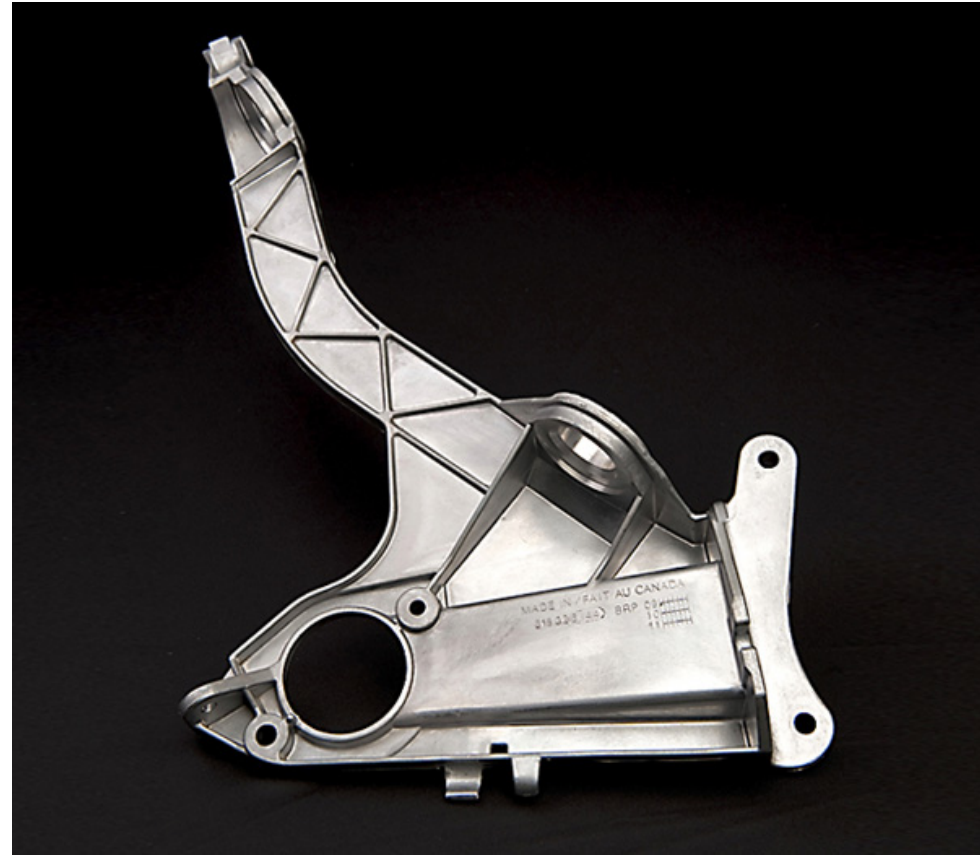

## Outline

- Aluminum Content in Automotive - The opportunity for diecasters
- **Requirements for High Integrity Aluminum HPDC**
- Success factors for high integrity HPDC with Technological Solutions & Case Studies
- Alloys and tempers for structural diecastings
- Products and Services for you
- Summary and Q & A

# Requirements for high integrity diecastings

- *Weight reduction*
  - *Part integration*
  - *High mechanical properties*
  - *Crash performance*
  - *Corrosion resistance*
  - *Weldable / heat treatable (blisters!)*
  - *Surface quality (esp. joining / contact surfaces)*
  - *Distortion free with tight tolerances*
  - *Pressure tightness*
  - *...*
- Typical mechanical properties:*
- |                       |            |
|-----------------------|------------|
| YS                    | 100/120MPa |
| UTS                   | 180MPa     |
| EI                    | ≥10%       |
| Bending angle (d=2mm) | ≥50/60°    |

# Requirements for high integrity diecastings

**Crash performance: Static loading of 25 lb. drive shaft housings illustrates Mercalloy's far superior energy absorption**

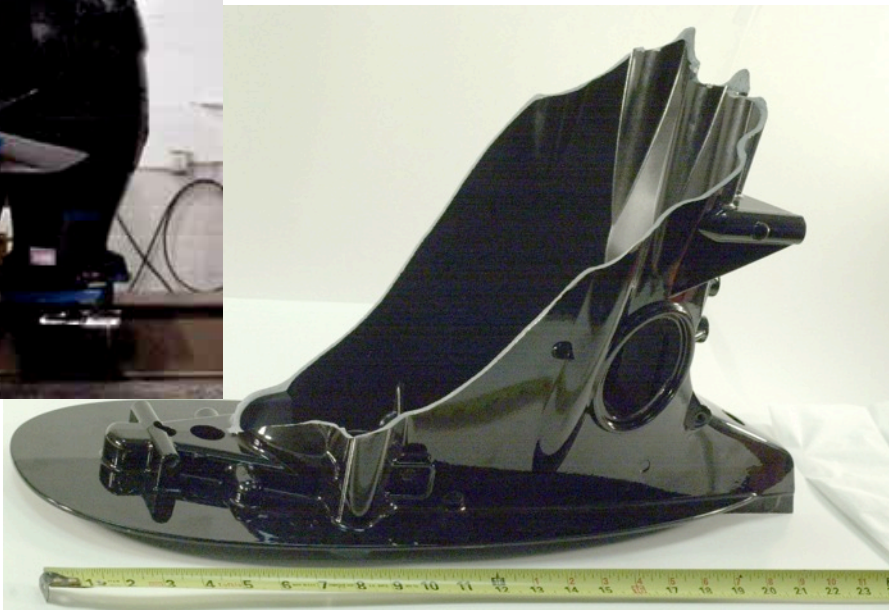

*Alloy: XK 360 with 1.3% max Fe  
One sudden, fast-propagating failure mode [in less than 100 milliseconds]*



*Alloy: **Mercalloy 367** - Crush-like failure never splitting completely – Honorable Mention in 2010 NADCA Casting of the Year Competition*

*Courtesy of MERCURY MARINE, a division of BRUNSWICK CORPORATION*

# Requirements for high integrity diecastings

## Typical Diecasting Defects

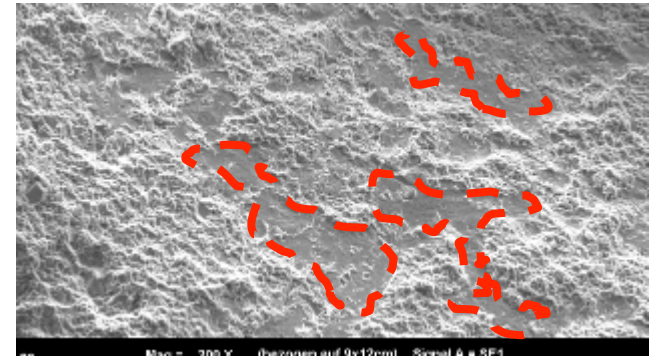
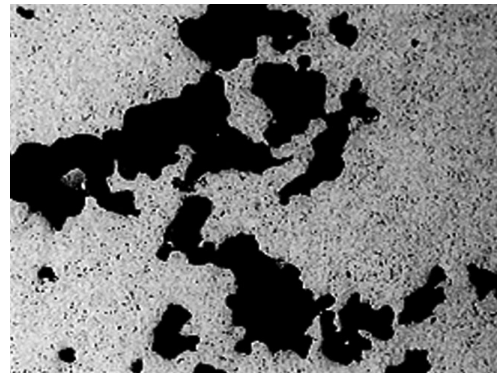
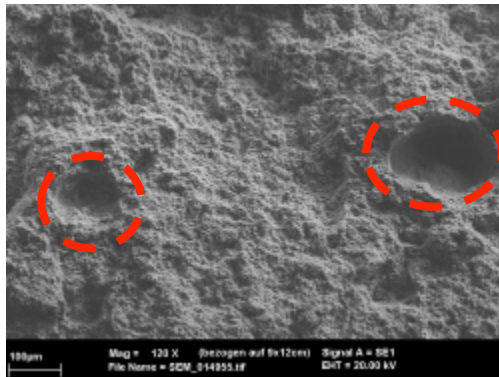

*Oxide inclusions*



*Gas porosity*

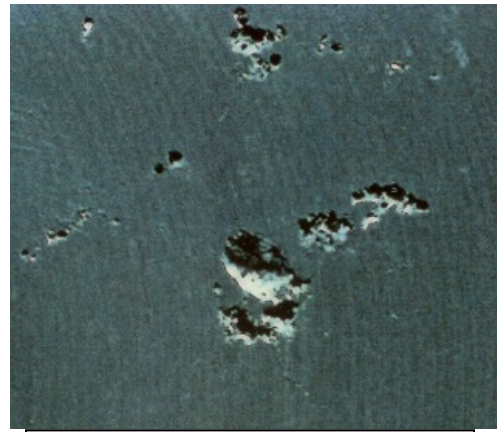

*Shrinkage porosity*



*Sludge particles*

*Other inclusions, etc.*



## Factors affecting die-casting quality

- Alloy composition and impurity
- Metal quality (oxides, hydrogen content, sludge, dross, other inclusions)
- Metal temperature, treatment, transfer, delivery to shot sleeve
- Die-casting machine (size, type, equipment)
  - Clamp/platen: clamp pressure/platen programmable
  - Shot end: shot speeds/profile, pressure, closed loop control
- Monitoring/Control system:
  - for all critical process parameters
  - full machine diagnostics
  - graphical user interface (HMI) provide SPC

## Factors affecting die-casting quality

- Shot tooling:
  - Cold chamber (proper size, internal temperature control, etc.)
  - Shot tip (with ring to create seal and internal cooling),
  - Plunger lube (type and application)
- Die-casting dies / gating design / overflow design
- Part design (wall thickness, changes, etc.)
- Die temperature
- Lubricant type, application and efficiency
- Vacuum system: level & type / cavity pressure / control
- Part extraction and quench system
- Trimming
- Heat treatment and other process steps

# Requirements for high integrity diecastings

## Porosity inside Die Castings

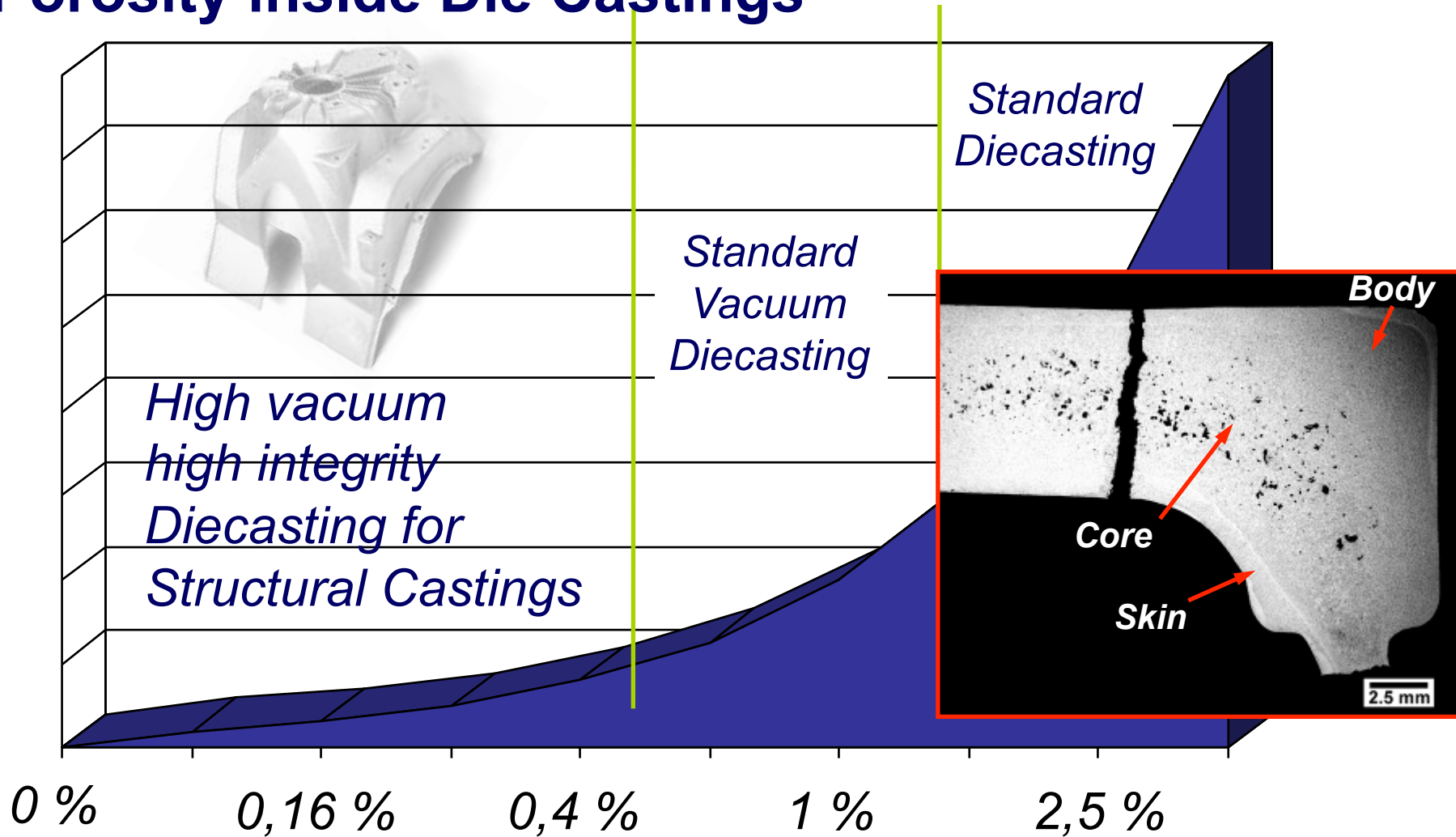

## Outline

- Aluminum Content in Automotive - The opportunity for diecasters
- Requirements of High Integrity Aluminum HPDC
- **Success factors for high integrity HPDC with technological solutions & case studies**
- Alloys and tempers for structural diecastings
- Products and services for you
- Summary and Q & A

## Complete Die Casting Process Technology

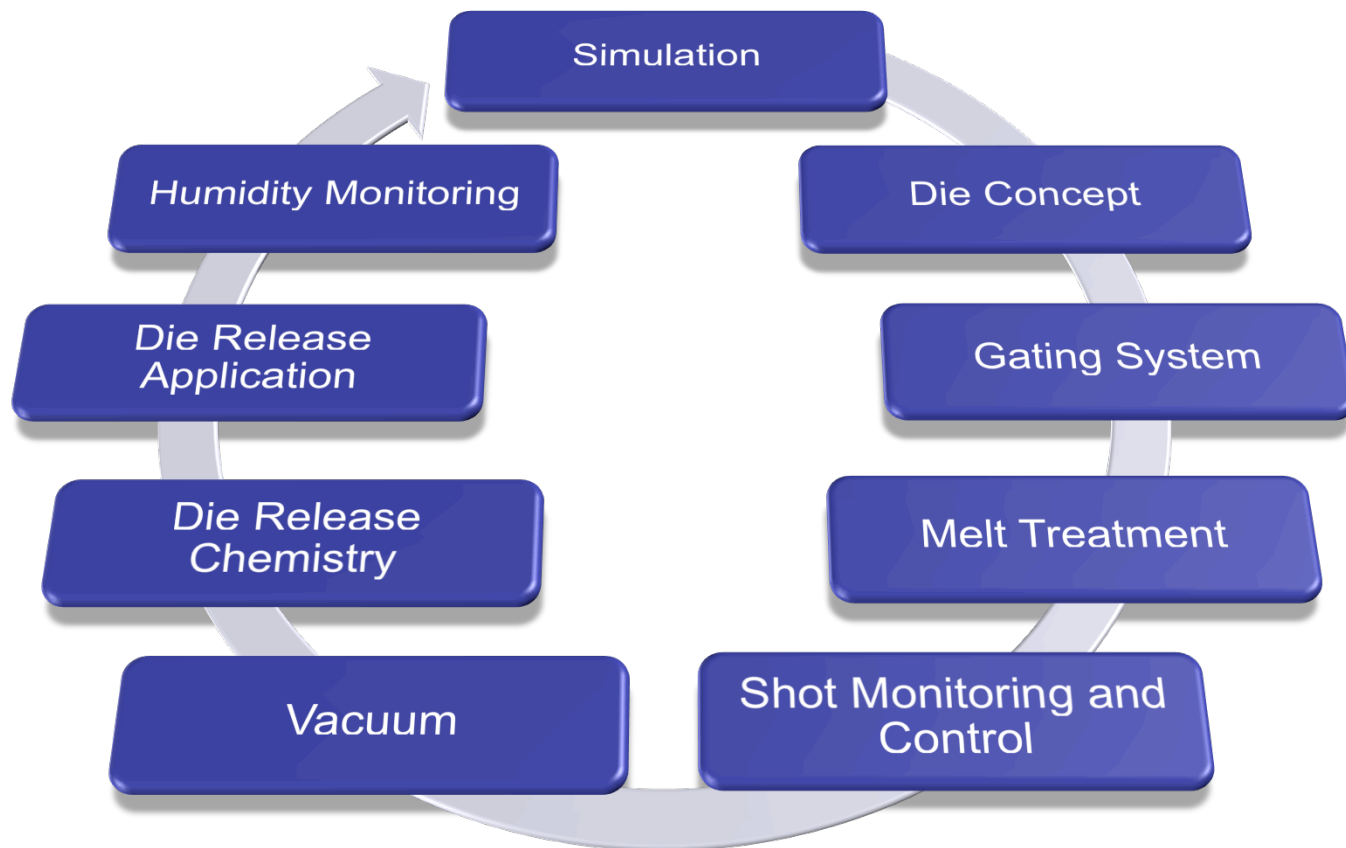

## Typical Process Chain for Structural Castings

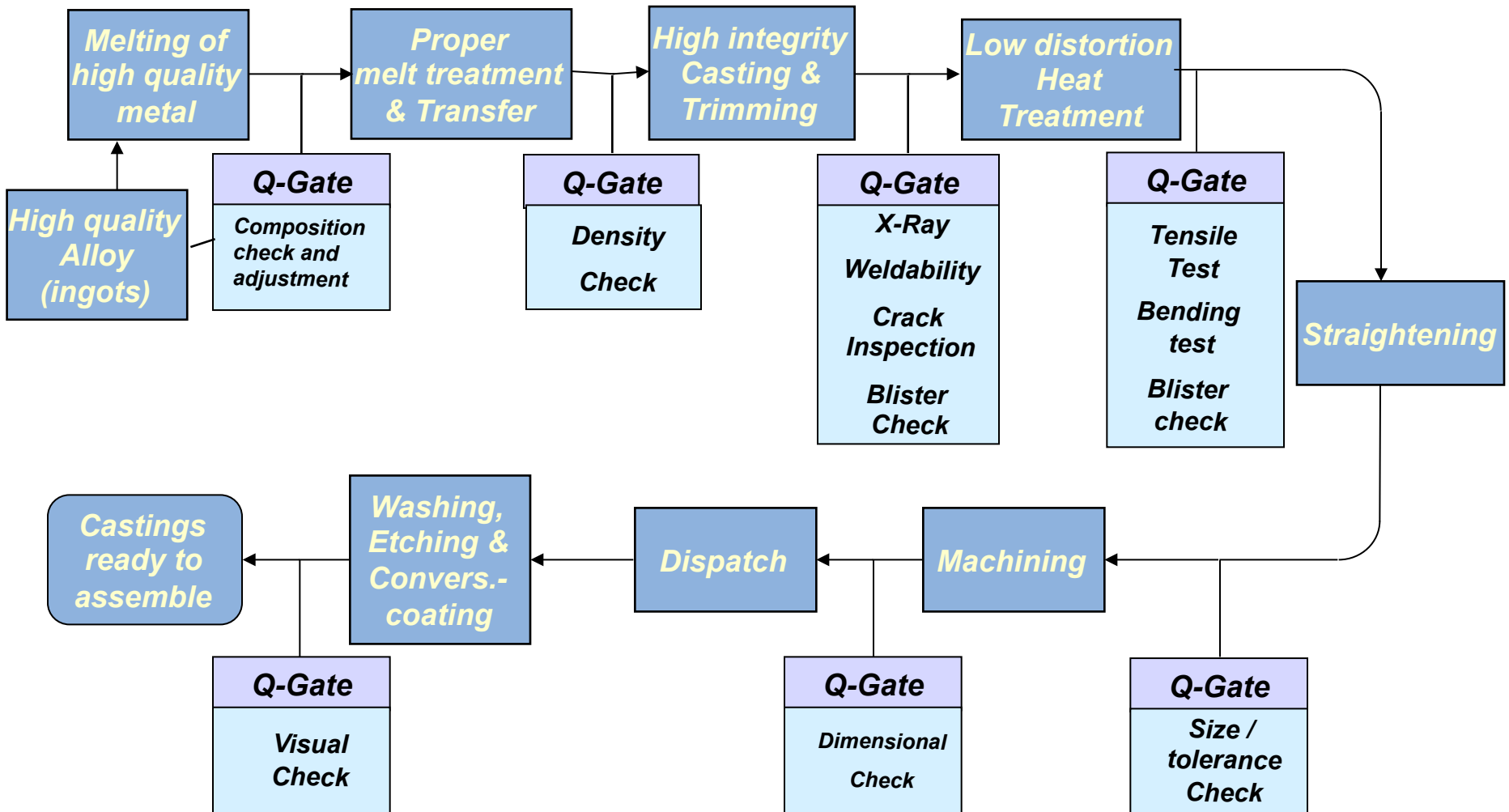

## Melting, melt treatment & transfer

Items to pay attention to:

- Oxides
- Hydrogen
- Sludge
- Dross
- Other inclusions

Measures to be taken:

- Proper temperature control of melt
- Avoiding excessive turbulences/splashing
- Degassing
- Fluxing
- Filtering
- Settling

$$\text{"Sludge" Factor} = (1 \times \%Fe) + (2 \times \%Mn) + (3 \times \%Cr)$$

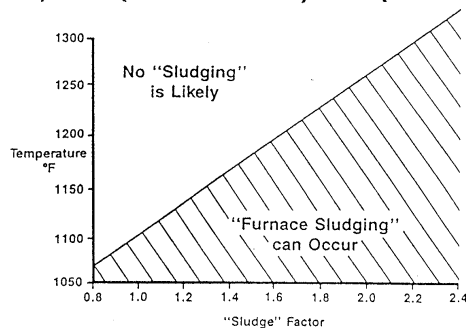

## Melting, melt treatment & transfer

Impact of filtering on fluidity

It is a better and more efficient to filter the metal than to increase the melt temperature!

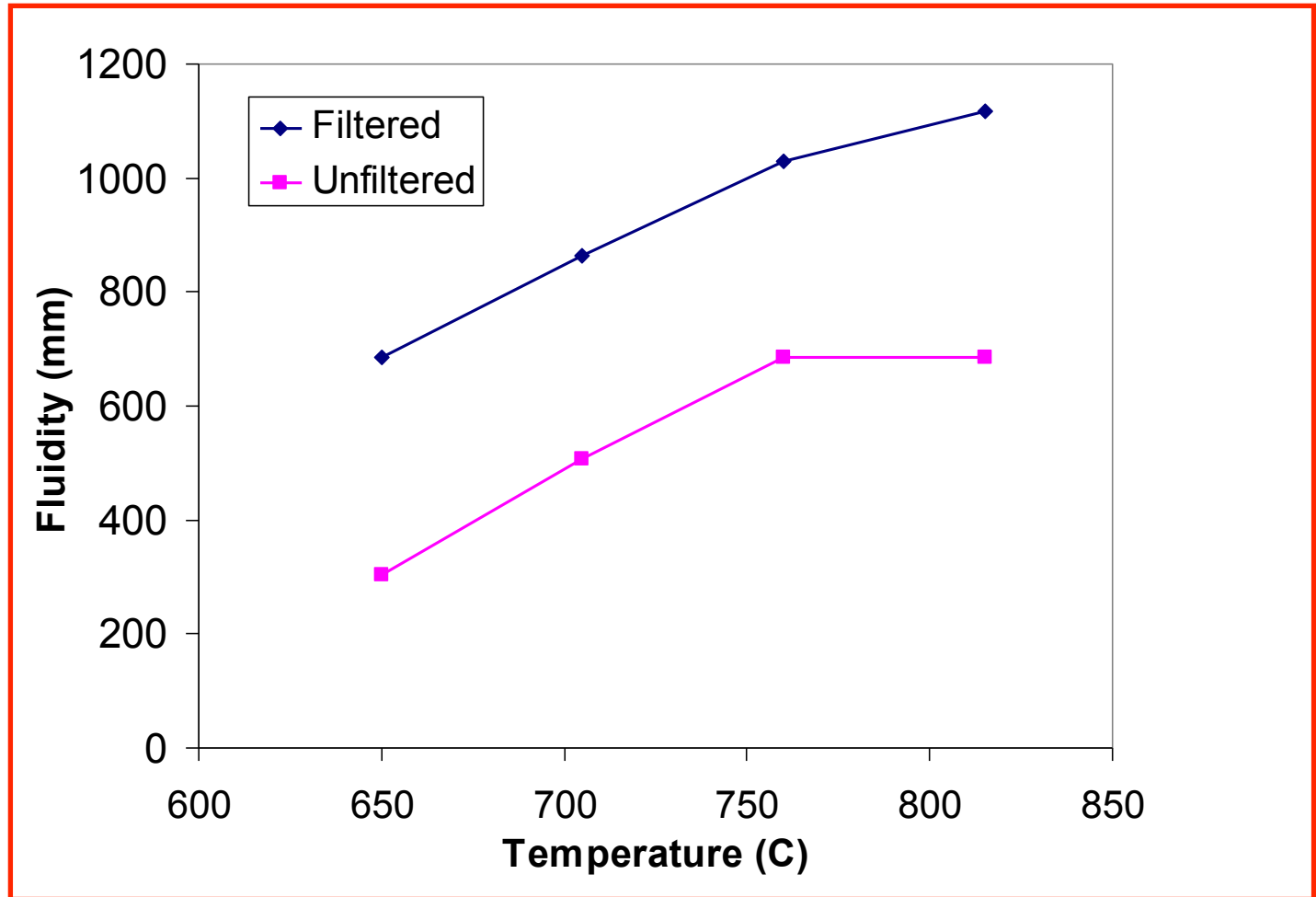



## Melting, melt treatment & transfer

### Degassing

*Removal of **hydrogen** from molten aluminum*

*Sparging with dry inert gas (Nitrogen or Argon)*

*Reduces gas porosity in castings*

*Not standard in standard HPDC*

### Fluxing *(Drossing and cleaning fluxes)*

*Use of reactive gases or salt fluxes to remove **dirt** (oxides) from molten aluminum*

*Aim to make inclusions stick to surface flux layer or flux films inside inert gas bubbles (removal to dross layer to be skimmed off)*

## Melting, melt treatment & transfer

*Any metal “waterfall” in the metal transfer will generate oxide inclusions!*



*Traditional metal transfer into the holding furnace causes significant metal splashing ...  
... and represents also a safety hazard with liquid metal in high positions*

# Success factors

## Melting, melt treatment & transfer

## Støtek DosoTherm

### Examples: StrikoWestofen dosing furnace

*Pressurized dosing furnace with transfer launder and integrated porous plugs for continuous degassing.*

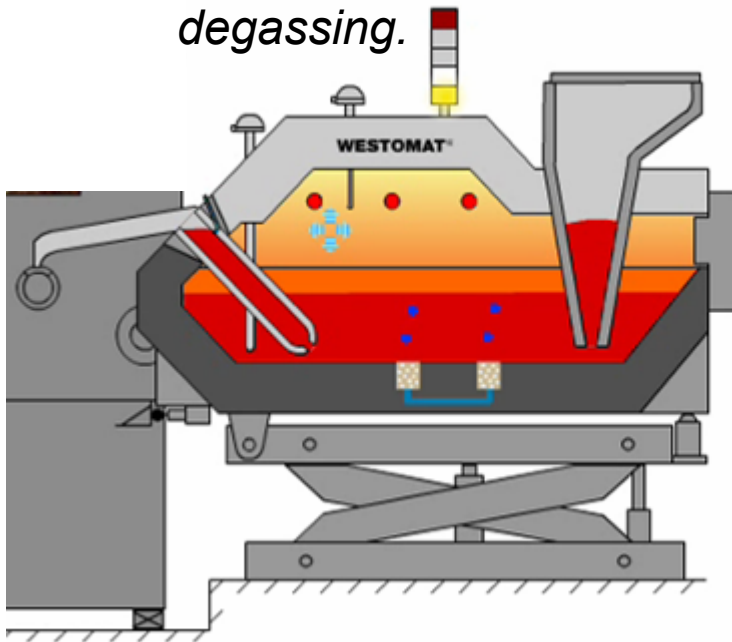

*Un-pressurized dosing furnace with integrated metal filter, featuring Støtek patented pump technology.*

## Melting, melt treatment & transfer

Melt transfer:  
Swivel Launder



*...has developed the design of the launder and the swivel jig in order to achieve a high melt quality level for high integrity diecastings.*

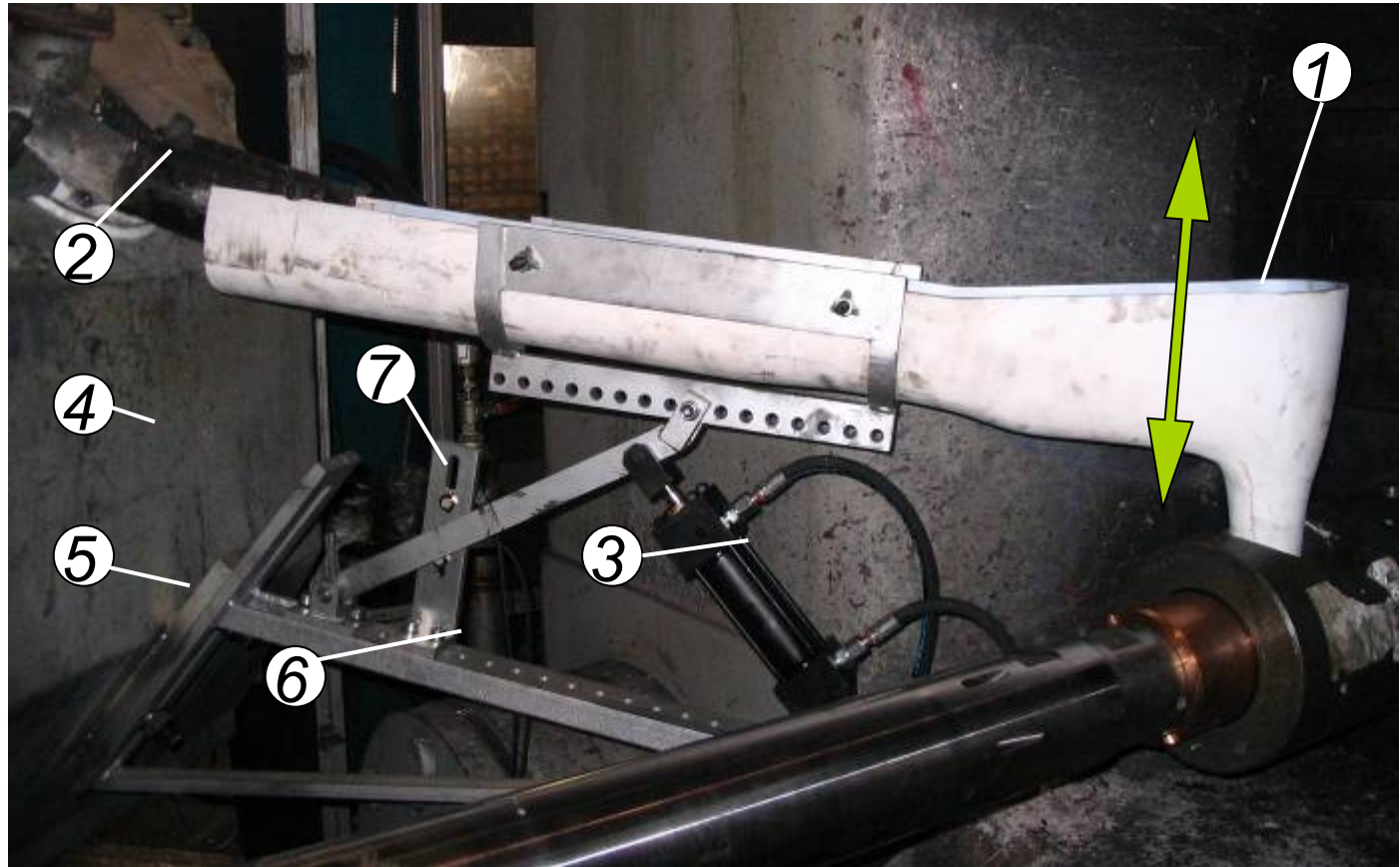

Ceramic launder (1); Furnace spout (2); Hydraulic cylinder (3); Holding furnace (4); Swivel jig height adjustment (5); Mechanical swivel jig (6); Position sensors (7)

## Numerical Simulation for Die Fill and Solidification

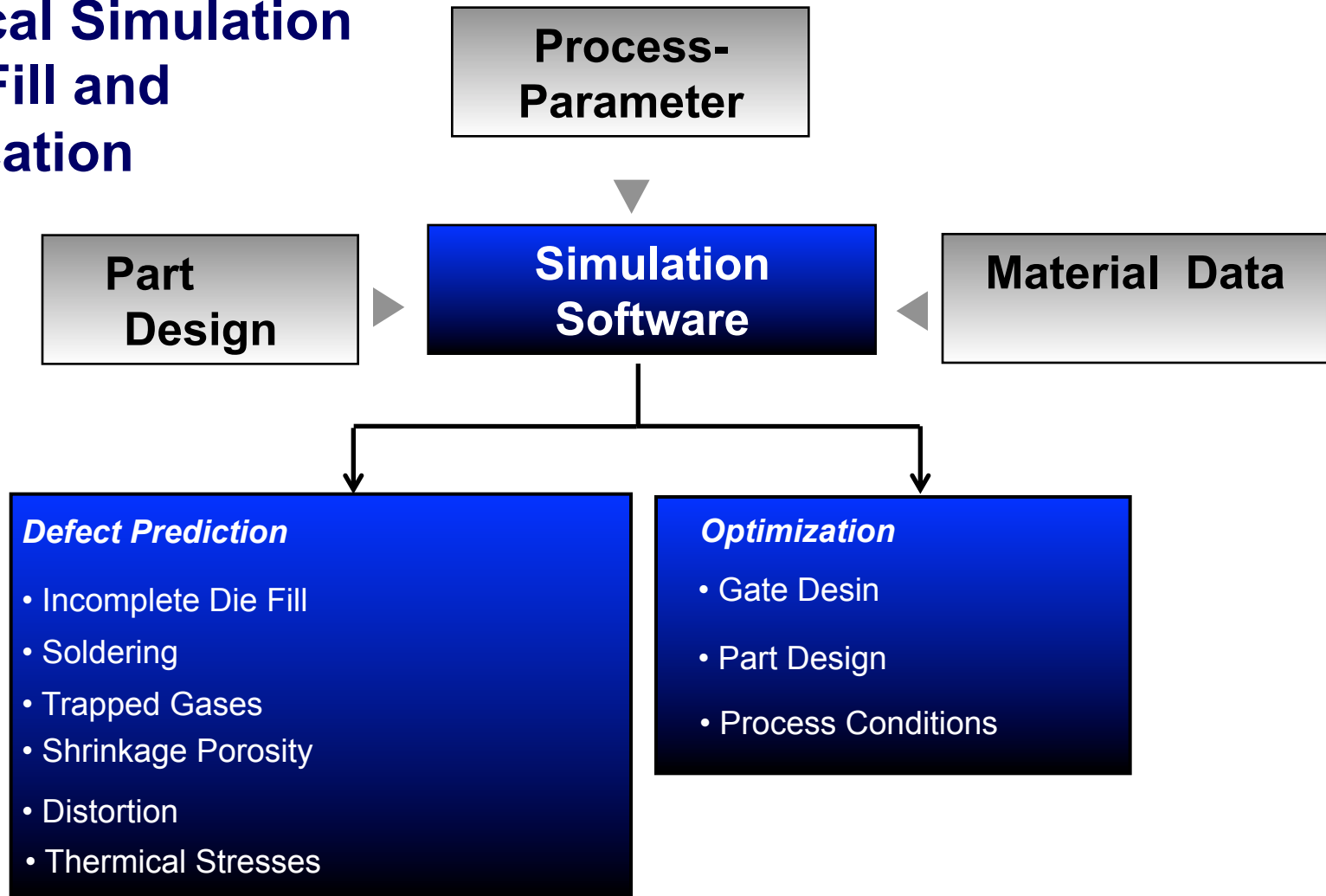

## Key to Success: Numerical simulation

- Runner design optimization - provide a continuous flow path into and through the part
- Overflow optimization (including vacuum valve position)
- Utilization of gates along nearly entire front edge of part
- Casting defects prediction
- Temperature distribution at surface of the cavity
- Velocity field in the liquid metal during die filling

## Key to Success: Numerical simulation

**Process  
Analysis –  
Die Fill  
(predicting  
porosity)**

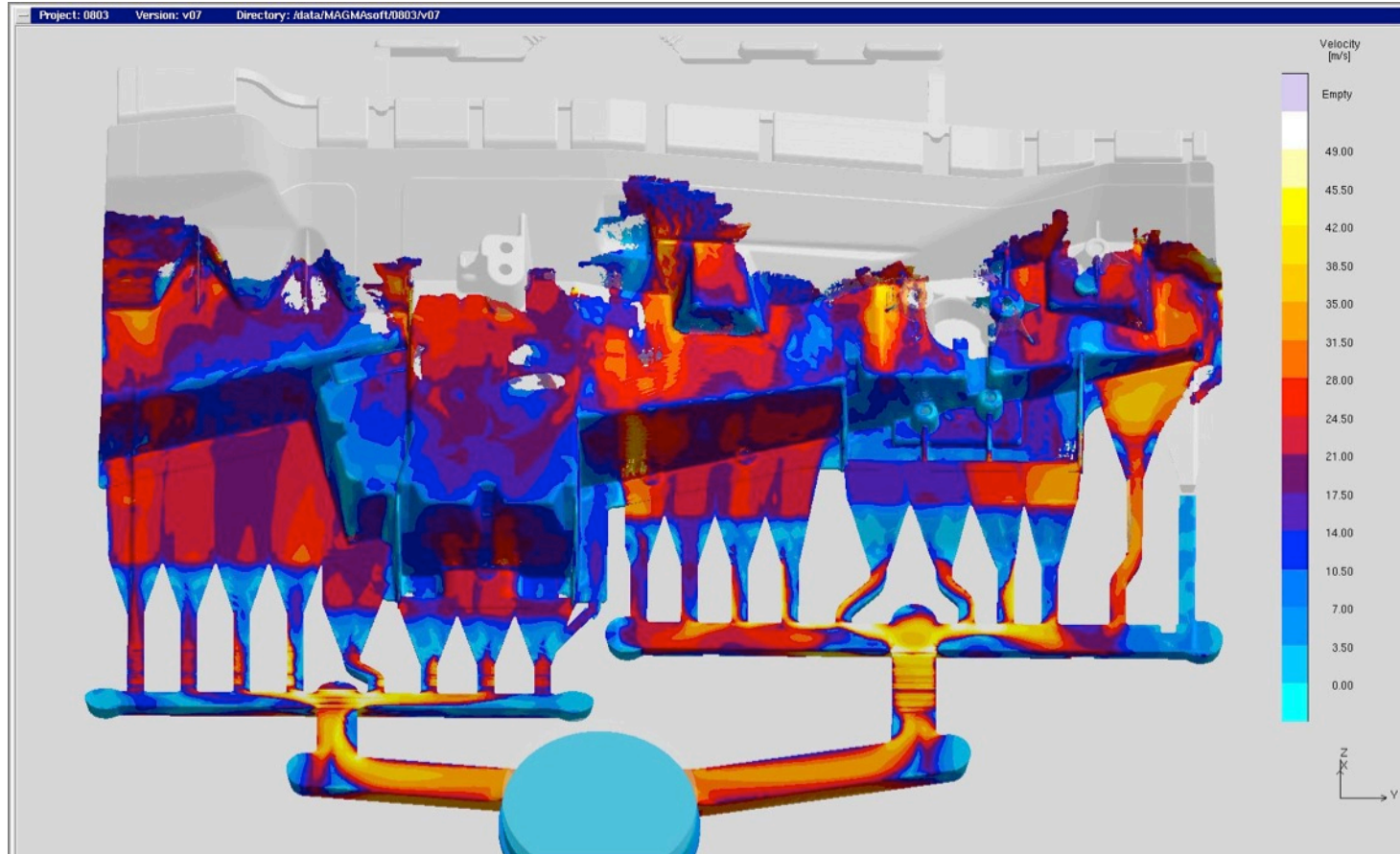

## Key to Success: Numerical simulation

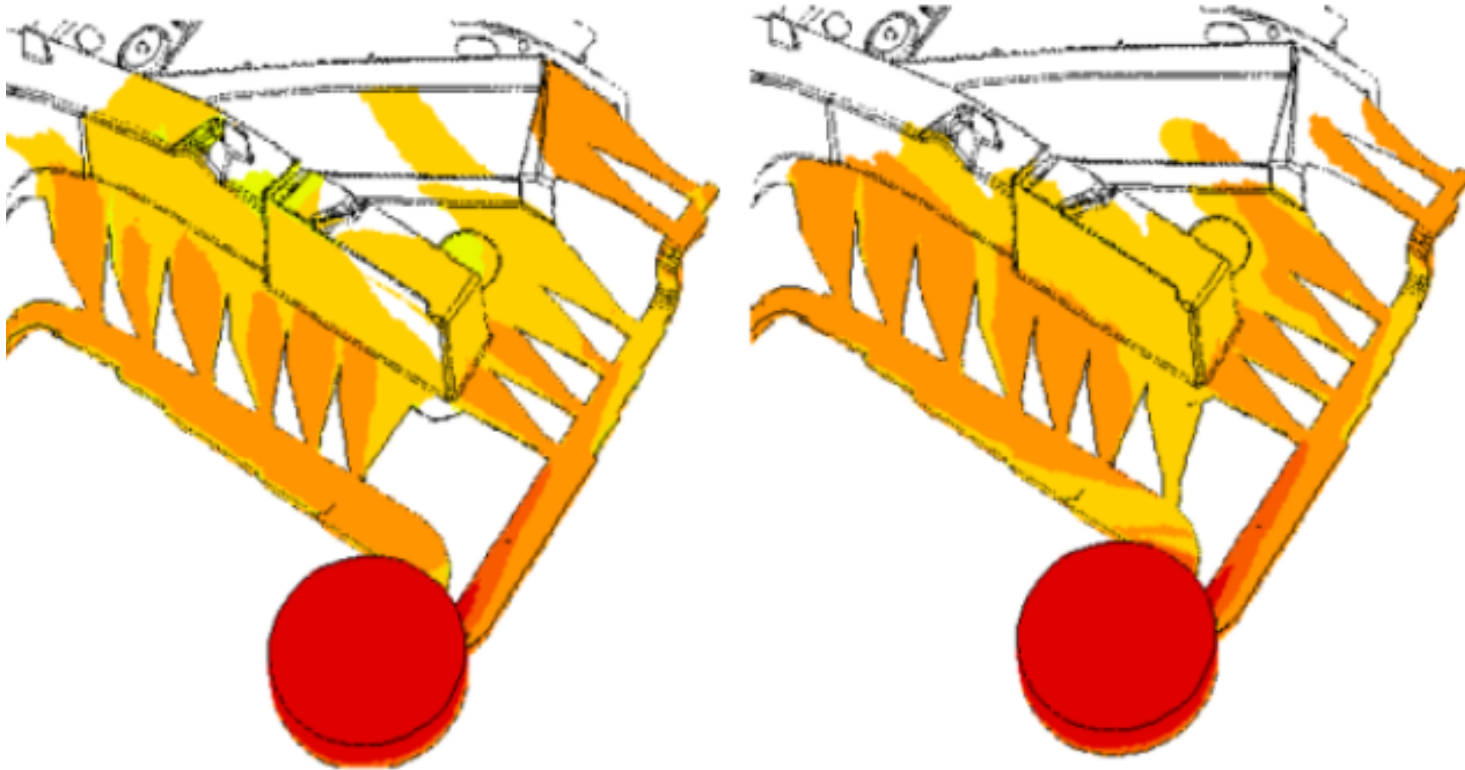

**1<sup>st</sup> flow simulation shows  
Overlapping flow paths**

**Optimized runner design  
eliminates trapped air**



## Key to Success: Numerical simulation, Die design and process control

Process  
Control –  
Die  
Temperature

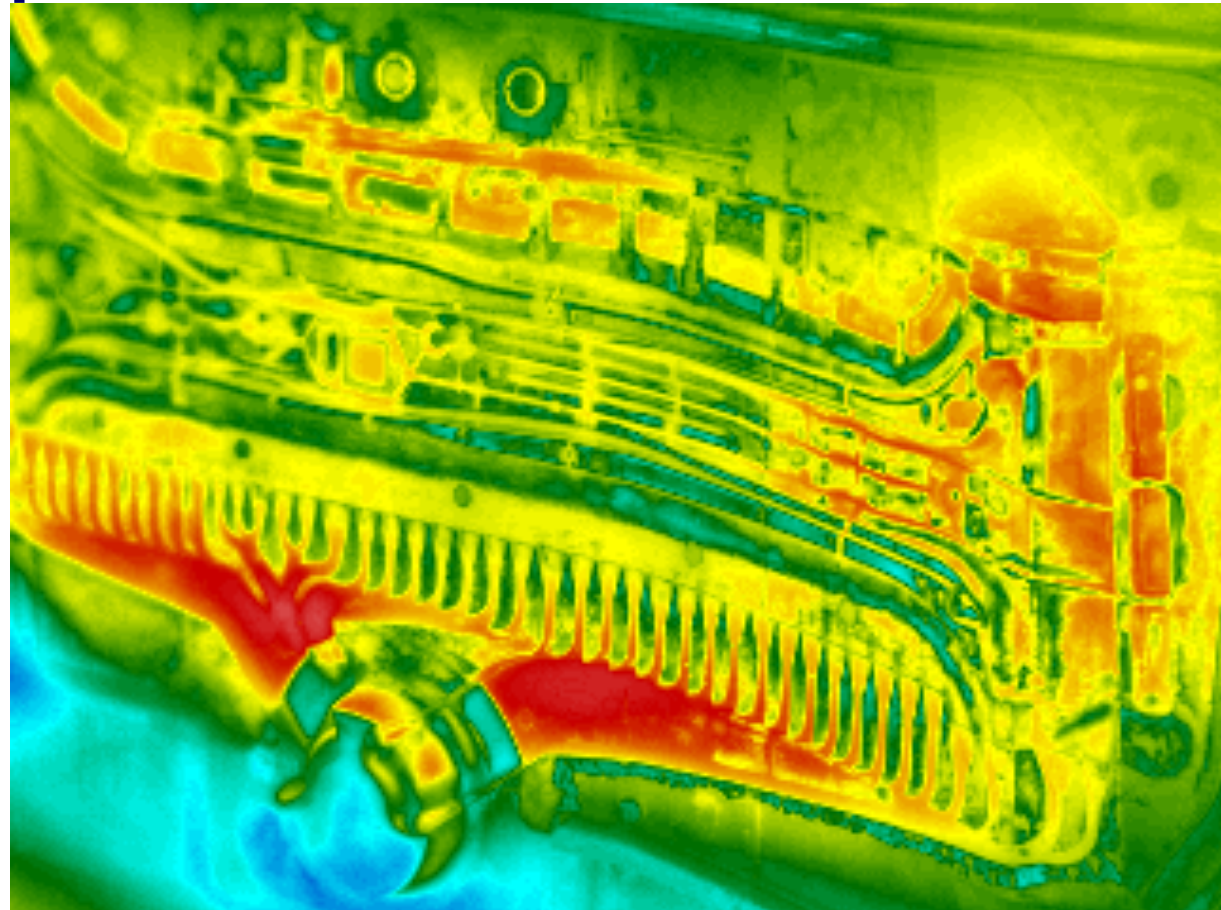

## Total Thermal Vision

- Real-time cycle-to-cycle die surface temperature monitoring.
- Cycle-to-cycle adaptive control of temperatures by interaction with the die lube reciprocator or robotic spray device.
- Read and store the die skin temperature at each cycle of the machine. It can monitor the die (outlined by laser pointers) with an IR camera mounted in a protective stainless steel case.
- High/Low limits can be set to alert the robot or unloading device to segregate a casting with an out of spec reading.
- Over extended production, this quick exit from non-productive warm up to production can have a big impact on company's OEE.



## Total Thermal Vision

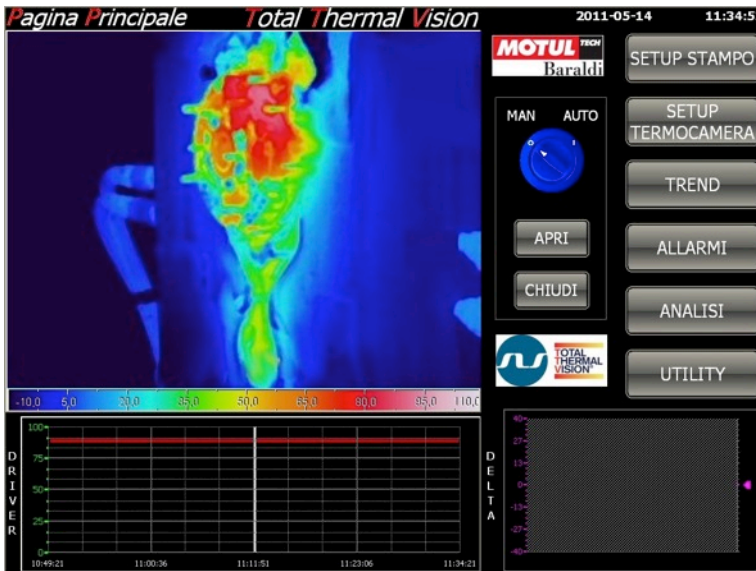

**TOTAL THERMAL VISION** can output warning signals, based on predetermined threshold values, and further alarms to **Keep under control & Guarantee your process, and Safeguard the Die**

- to select up to **10 different areas** on the die surface, having different shapes and dimensions.
- for each of them, can be measured and recorded, every cycle, or with prearranged frequency:
  - Max Temperature before and/or after lubrication,
  - Temperature trends,
  - Data Processing: differences, profiles, histograms ... **THERMAL MOVIES** ... etc.

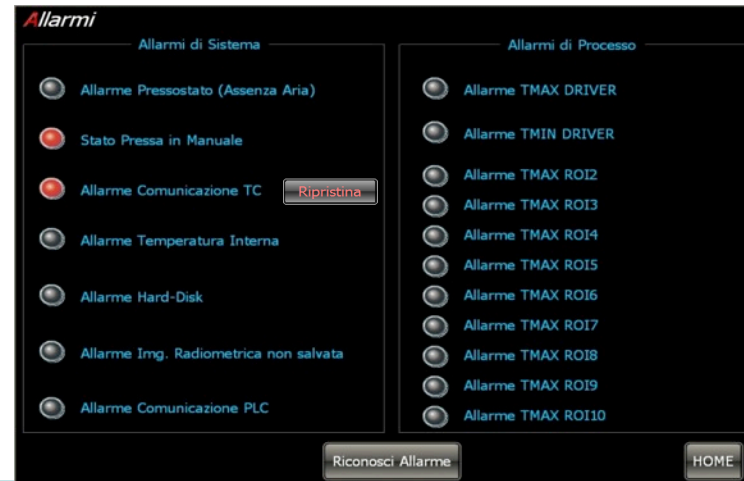

## Key to Success: Die design

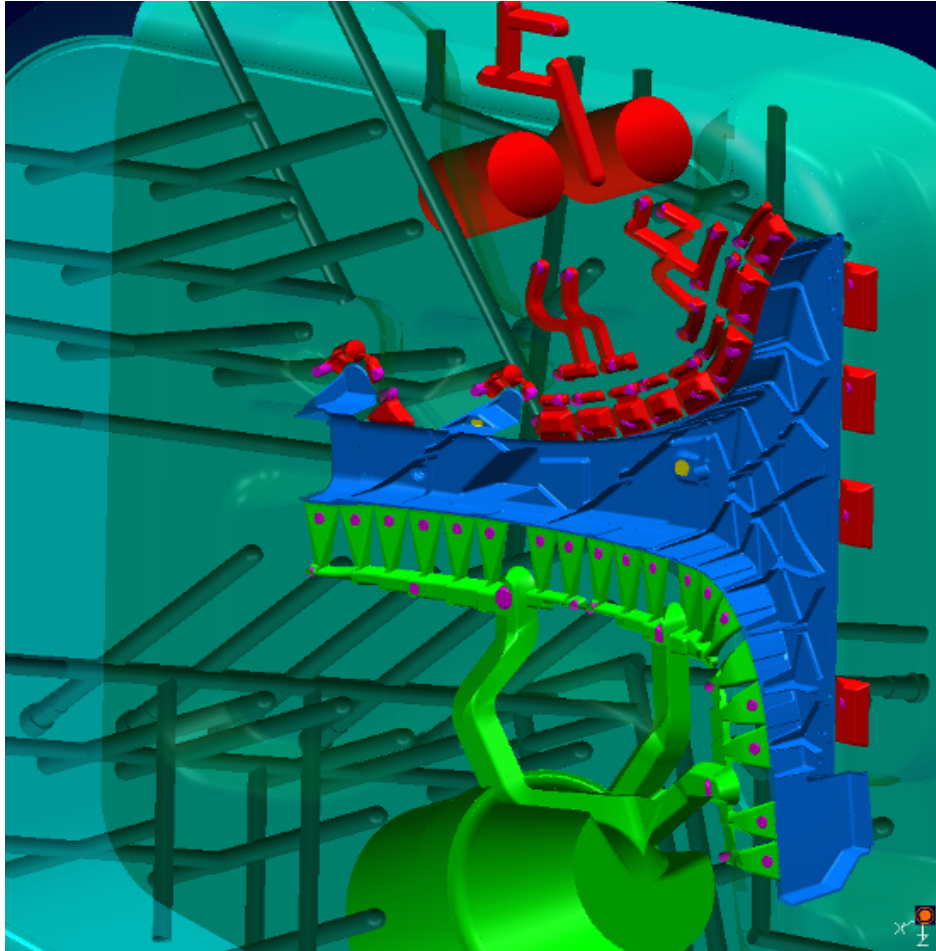

*Moving half of die with gating system (green) and overflow/vacuum system (red)*  
*Part contour (blue)*  
*position of ejector pins (purple)*  
*cooling/heating systems (dark green)*

## Key to Success: Die design

- O-Rings are used extensively on tooling to prevent leaks
- Thermal isolation plates are used to improve warm-up time
- Multiple short hot oil zones are utilized to control die temperature



## Key to Success: Product Development

### ■ Component Design

- Robust designs meet both functional & manufacturing requirements
- Robust component designs lead to higher quality products
- Design engineers should collaborate with casting engineers in the early stages of product development

### ■ Gating and Die Design

- Simulation is a must
- Gating design is important
- Vacuum gating is also important and often overlooked

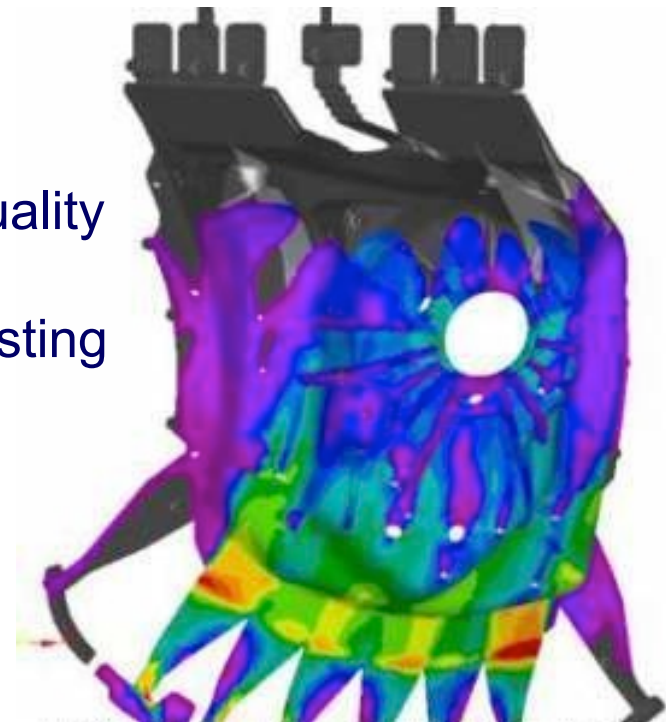

## Key to Success: Process Monitoring/Control

Successful high integrity die cast process requires advanced process controls and monitoring systems - real time adjustable control system (i.e. closed loop)

### ■ Shot control

- Reduce Air Entrapment during Slow Phase
- Smooth Metal Flow & Flexibility of adjustments during Fast Shot/ Fill Phase
- Repeatability regardless of changes
- Deceleration for Low Impact
- Programmability (in engineering units for fast and repeatable set-ups; store, recall and download set-ups)

## Key to Success: Process Monitoring/Control

Successful high integrity die cast process requires advanced process controls and monitoring systems - real time adjustable control system (i.e. closed loop)

### ■ **Vacuum Monitoring/Control System**

- Apply vacuum during fast shot - repeatability is key
- Detecting leaks or blockages is crucial
- Monitoring system can be used to quickly troubleshoot equipment (improved uptime)

### ■ **Die cavity sensors:**

- thermal history of die
- measurement of pressures during solidification



## A Proactive Approach to Process Control

- **Monitor key variables**
  - Shot-end Hydraulic characteristics
    - Position, Velocity, Pressure, Vacuum
  - Derive key process parameters like:
    - Biscuit length, intensification pressure, intensification squeeze
  - Furnace/metal and die temperatures.
  - Tie-bar stress
  - Cycle times.
- **Casting characteristics are calculated and reported by monitoring equipment.**
- Design experiments to understand relationships and causes of variation
- Accrue production information including scrap and downtime data

## Sure-Trak2™ Real Time Shot Control System



- Real time control of shot velocity.
- Six programmable shot steps with low impact.
- Six programmable limit switches.
- Proportional – Integral control loop implemented in firm ware
- Programmable control parameters.
- Programmable dither.

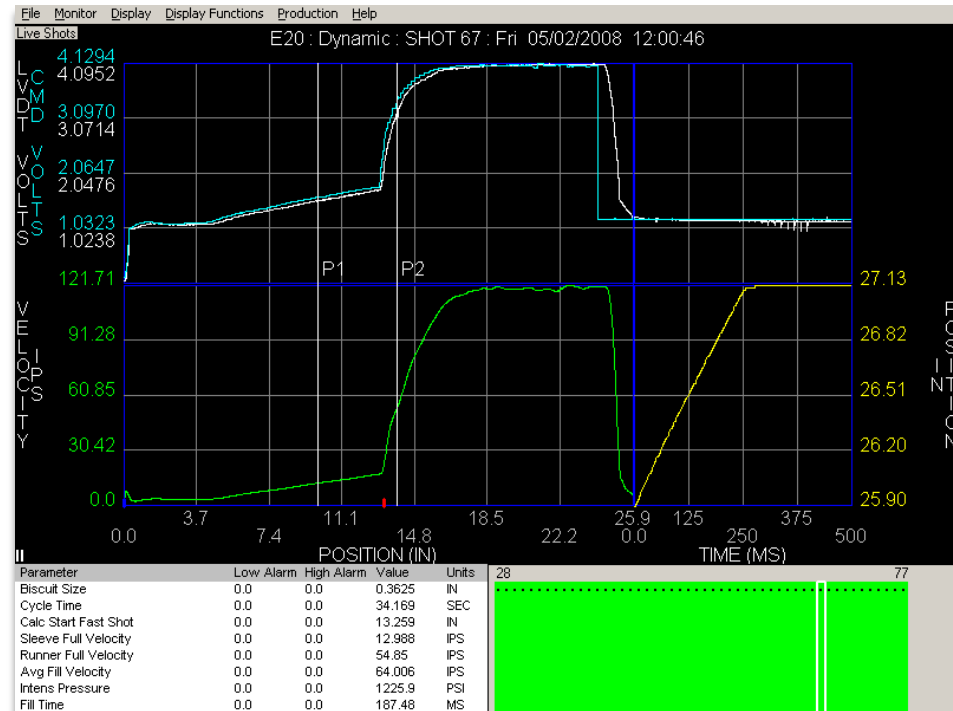

Produce Precise and Repeatable Injection Control

## Two Monitoring Methods

### Portable Monitoring

- Regularly check variables using portable process monitors
  - Labor intensive and prone to error.
  - Too infrequent to catch sporadic events.

### (Plant Wide) Continuous Monitoring

- Full time monitoring identifies each time a key parameter is out of specification.
  - Alarms alert operator as specifications are not met with immediate analysis.
  - System monitors **24/7**

## Plant Wide Continuous Monitoring (continued)

- Sporadic machine problems can be identified and solutions developed from real data.
- Automatically segregate suspect and “start up” castings. Greatly reducing the incidence of “cold shots” reaching the customers.
- Permanent installation means cabling and sensors can be shielded from the environment for longer life and lower maintenance.

## Plant Wide Continuous Monitoring (continued)

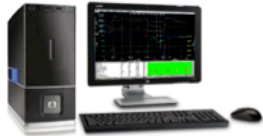

### REALTIME MONITORING & VISUALIZATION TERMINAL

Process, Production & Maintenance Personnel get instant access to process information from each machine

### PART TRACEABILITY

Automated Marking Systems

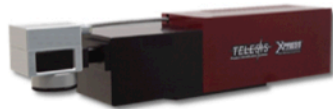

Unique ID  
2D Data Matrix  
or Pin Stamp

DCM Cell #1  
with Universal Data  
Collection Terminal

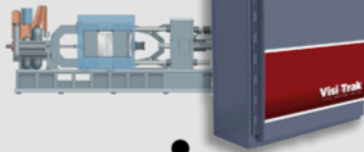

DCM Cell #n  
with Universal Data  
Collection Terminal

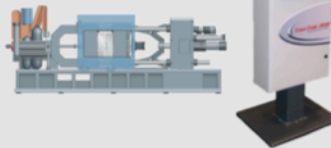

### QUALITY CONTROL DATA BACK-UPS

Automatic Quality Control Backup of data on shift, day, week, month and yearly basis



### PART INFO AND QUALITY CONTROL WORKSTATION

Q.A. and Plant Management



### REALTIME REMOTE WORKSTATIONS

Plant Engineering and Management - Complete Process Insight from the other side of the plant or across the globe.

### NETWORK

From DCM to Shop office, Back Office or Remote Locations



# Sleeve Fill Phase

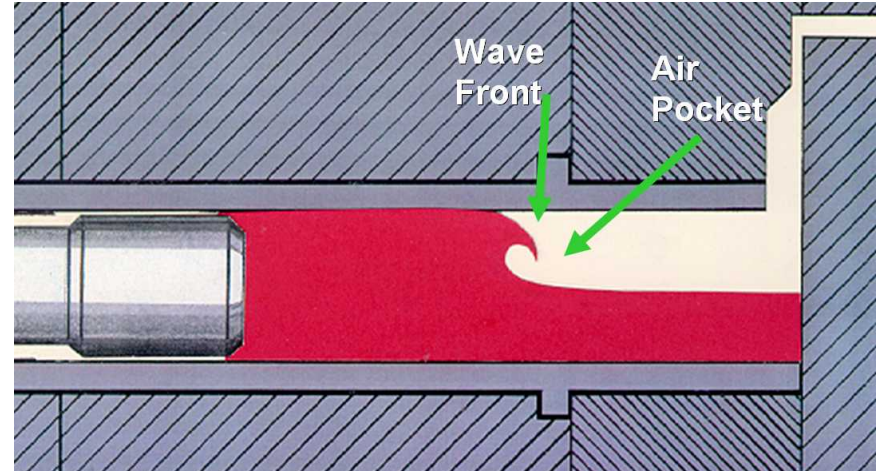
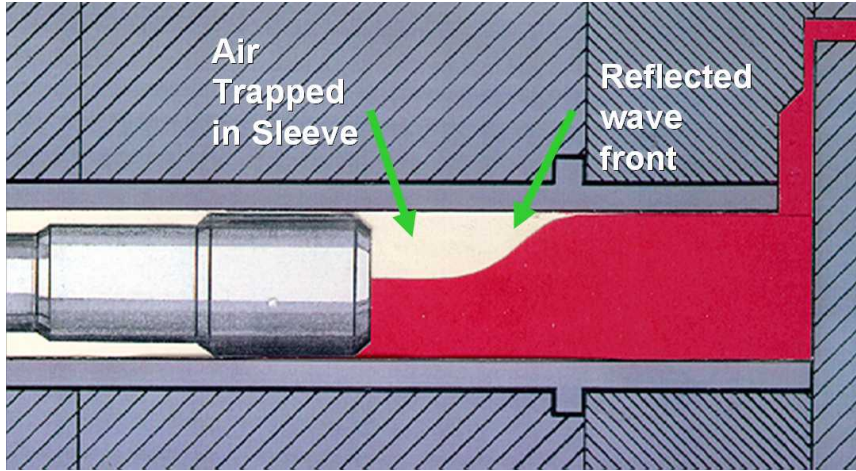

Too Slow?

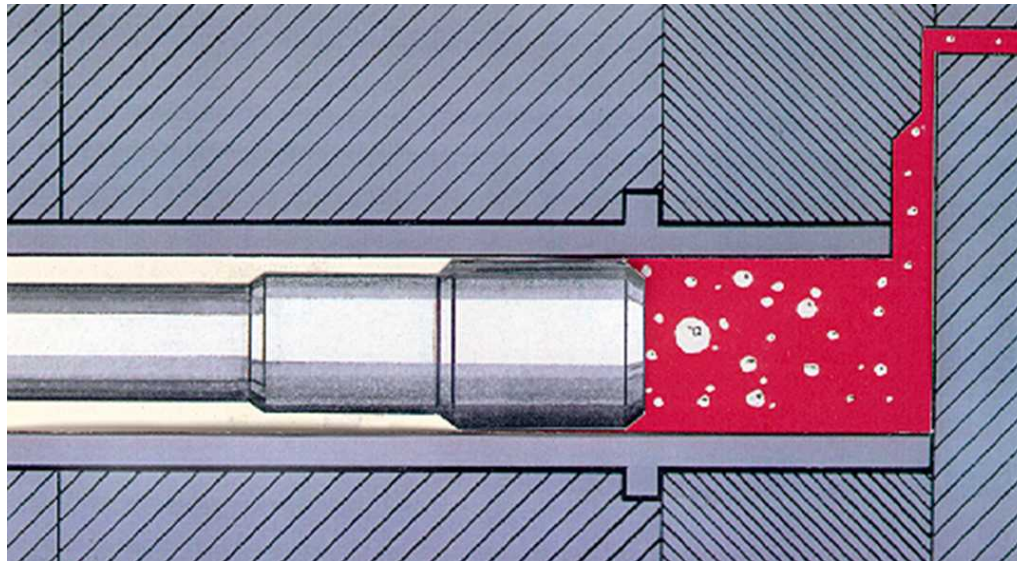

Too Fast?

# Cavity Fill Phase – Critical Slow Shot Velocity

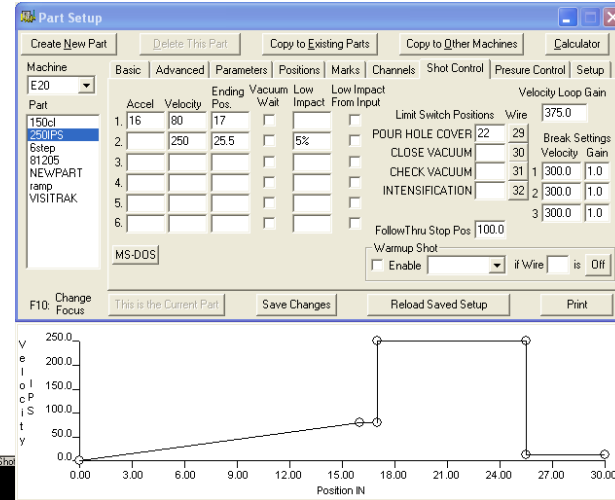
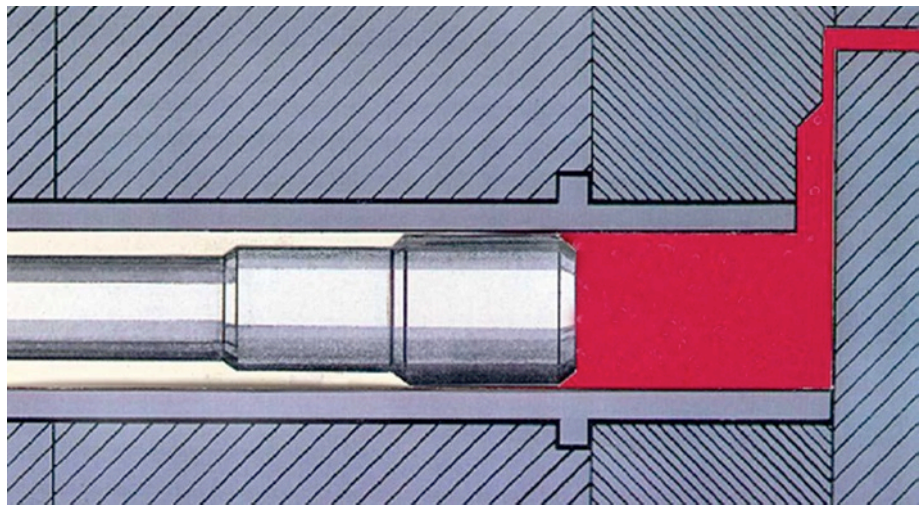
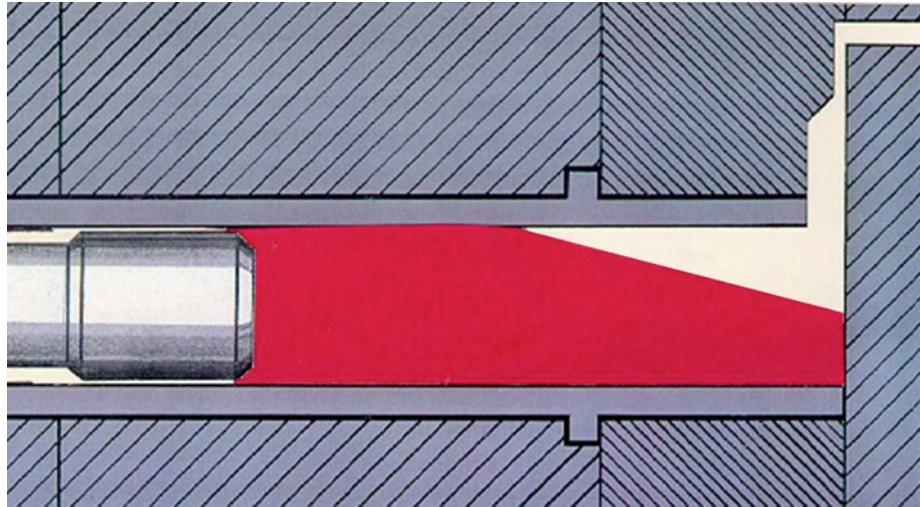

Constant  
acceleration

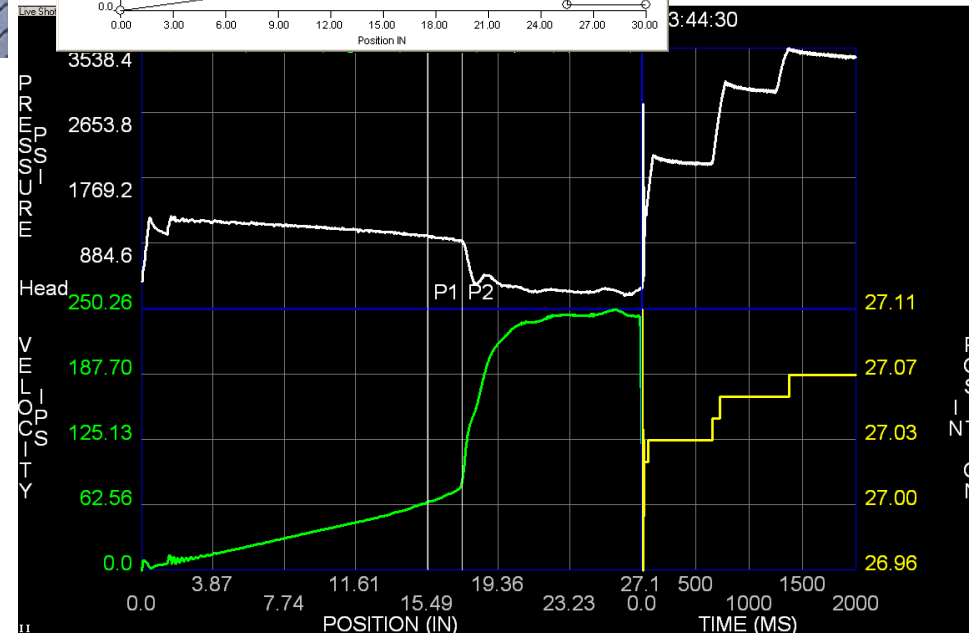

## Key to Success: Process Monitoring/Control

*Process Control - example: VISI-TRAK's SoftSHOT Technology*

- Design of the overflows to absorb kinetic energy and thus decelerate the shot system (positioned in the die where the final filling occurs)
- Ultimate pressure in the cavity area can be controlled to a level that the clamp end of the machine can hold closed, thereby eliminating flashes
- Smoothly decelerate the shot system automatically compensates for metal pour variation
- *Improves vacuum*
- *Less wear and tear on shot end clamp end*
- *Improves part quality*
- *Extends die life*



*Before*

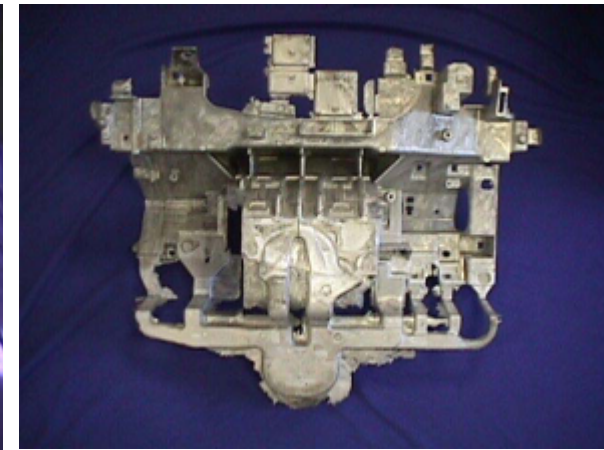

*Cadillac Instrument Panel*

*After*



## Key to Success: Process Monitoring/Control

### How Does The Sensor Work?

It detects variation in the magnetic field caused by the rod's grooved internal structure – at up to 480in per second at .0125" resolution.

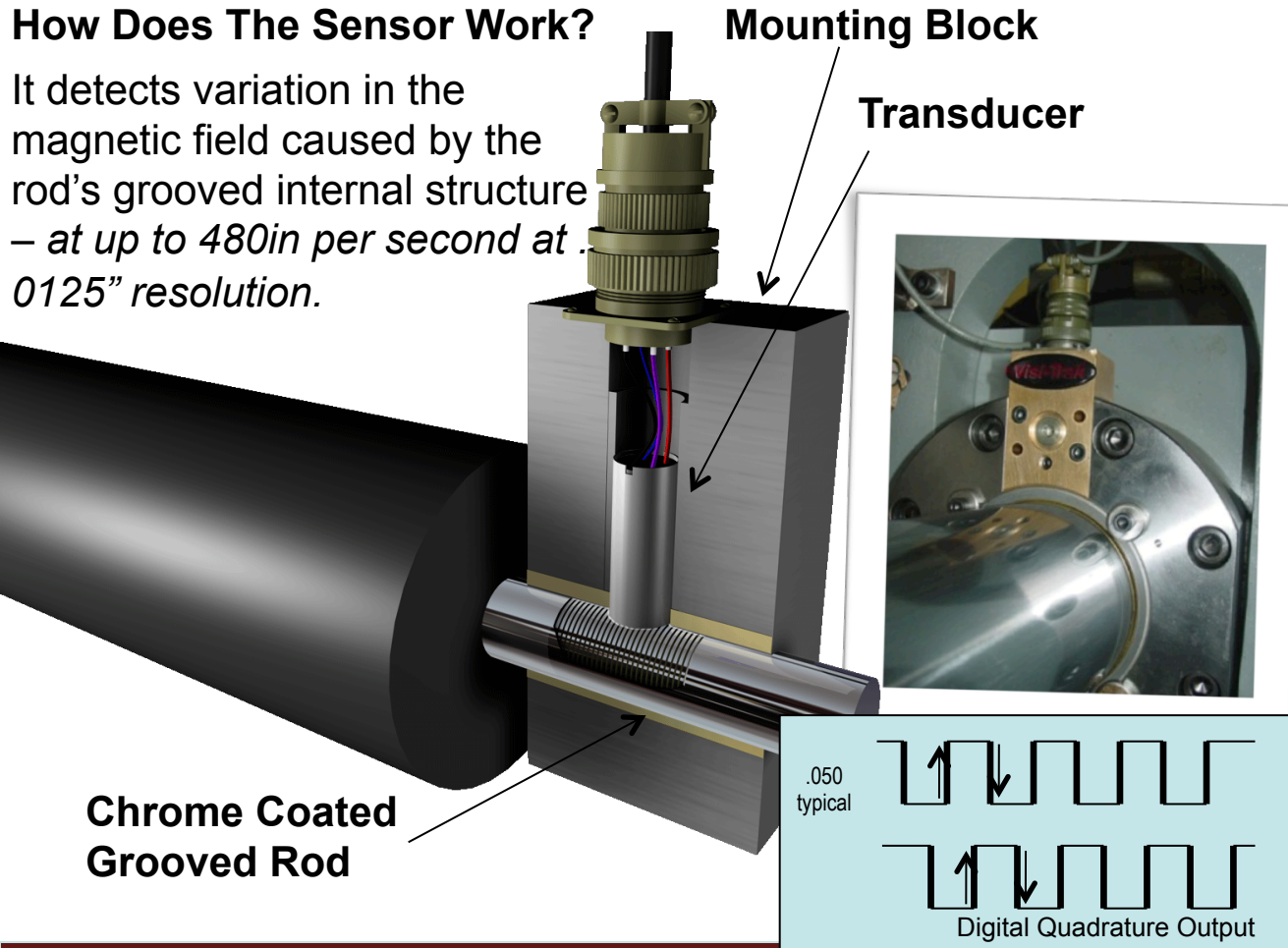

### TOUGH + RELIABLE

**Design Simplicity**  
for inherent reliability.

**Extreme Accuracy**  
up to 480IPS/12MPS.

**Non-contact sensor**  
minimizes equipment wear.

**No calibration or alignment**  
means no set-up problems.

**Proven Performance**  
for over 25 years.

**Easy to install & operate**  
nearly maintenance free.

## Visi-Trak SV Series servo throttling valves

- **Precise Slow-shot Speed Control** for reduced porosity
- **High Flow Rates** for explosive acceleration & deceleration
- **Fastest Response Time** for the most dynamic shot profiles
- **Easy To Implement** in a variety of styles and sizes
- **Rugged Design** for exceptionally long life

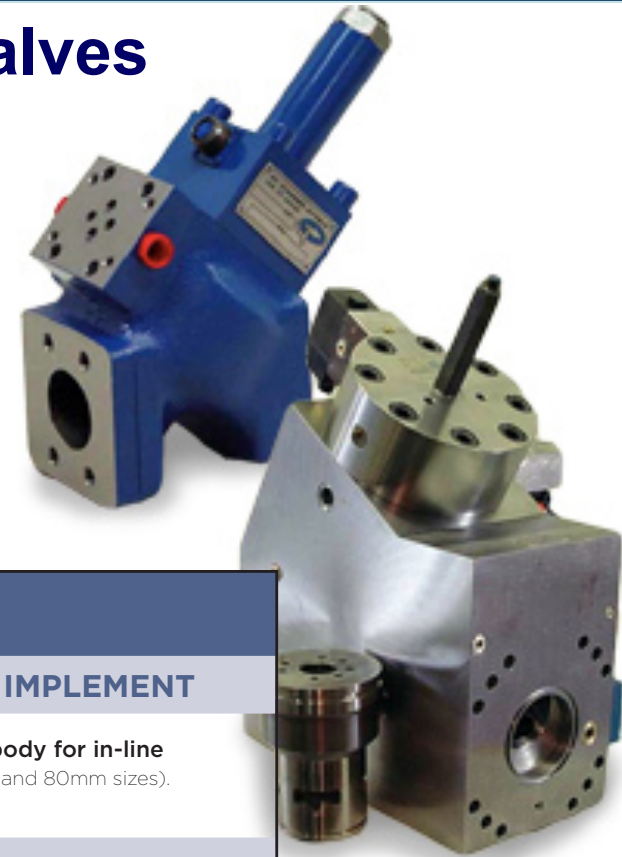

### WHY CHOOSE A SV SERIES VALVE?

#### DYNAMICALLY RESPONSIVE

Unique design enables **fine low speed control and very high flow rates**, allowing precise control over a broad speed range.

The **fastest response time** of any servo piloted throttling valve tested - instant response for even the most dynamic shot profiles.

Pressure rated up to 6000 PSI

#### TOUGH + RELIABLE

All working valve surfaces utilize **hardened & ground 8620 carburizing steel**, for exceptionally long life.

In-line version is **fully sleeved**, allowing replacement of any worn components, **for amazing valve life**.

Improved LVDT design eliminates leakage

#### EASY TO IMPLEMENT

Available in a **cast body for in-line installations** (50mm and 80mm sizes).

Available in **cartridge style for manifold mounting** for clean hydraulic designs (32 mm, 40 mm, 50 mm, 63 mm, 80 mm, and 100 mm sizes).

## Retrofit solution

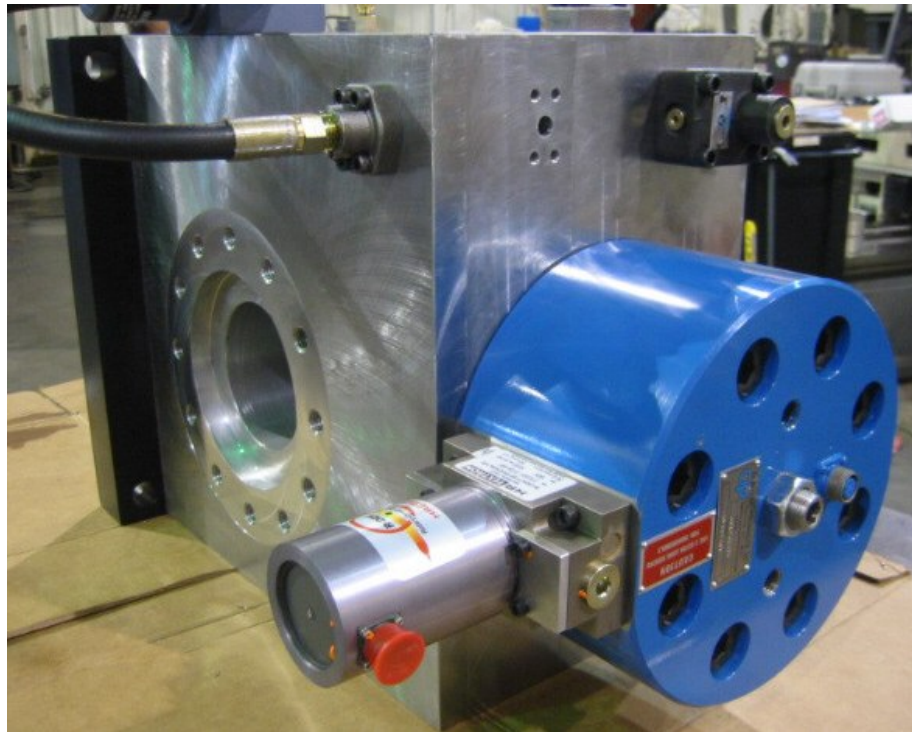

- Remove Binary II shot valve and manifold block
- Direct bolt-in replacement with:
  - Olmsted 80mm two-way, servo-piloted throttling valve slip-in cartridge format
  - Piloted by an H.R. Textron R-DDV servo pilot valve
  - PO check valve releases oil to retract the shot cylinder
  - Cartridge valve develops pressure to retract the shot cylinder
  - Cartridge filter ensures a clean oil supply

# Success factors

## Total-Trak HMI – PLC Front End

- **Monitor & control**, your entire automated machine cell.
- **Easy set-up** - restore saved jobs in seconds.
- **Complete I/O Diagnostics** for a comprehensive view.
- **Integrated control** with the True-Trak20/20™ or Sure-Trak2™.
- **Ladder logic display** options available.
- **Cost-effectively replace** your obsolete systems.

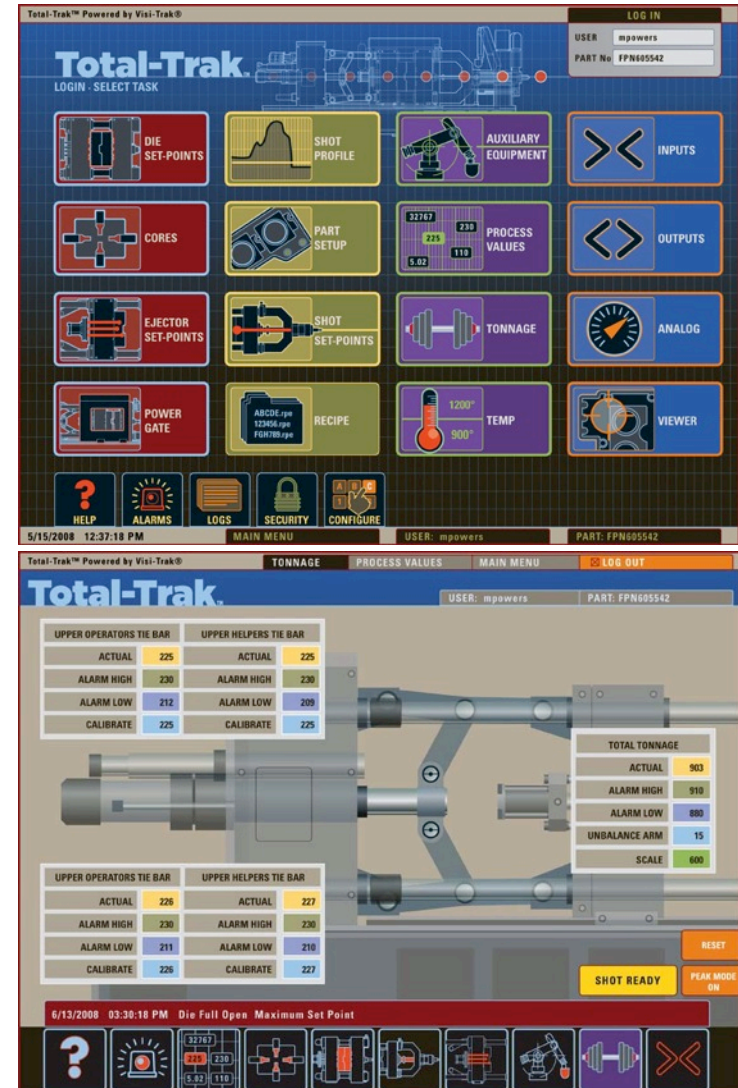

# Key to Success: Lubricant

Minimize evolution of gas (and subsequent entrapment in castings) resulting from reaction between lubricants and molten metal

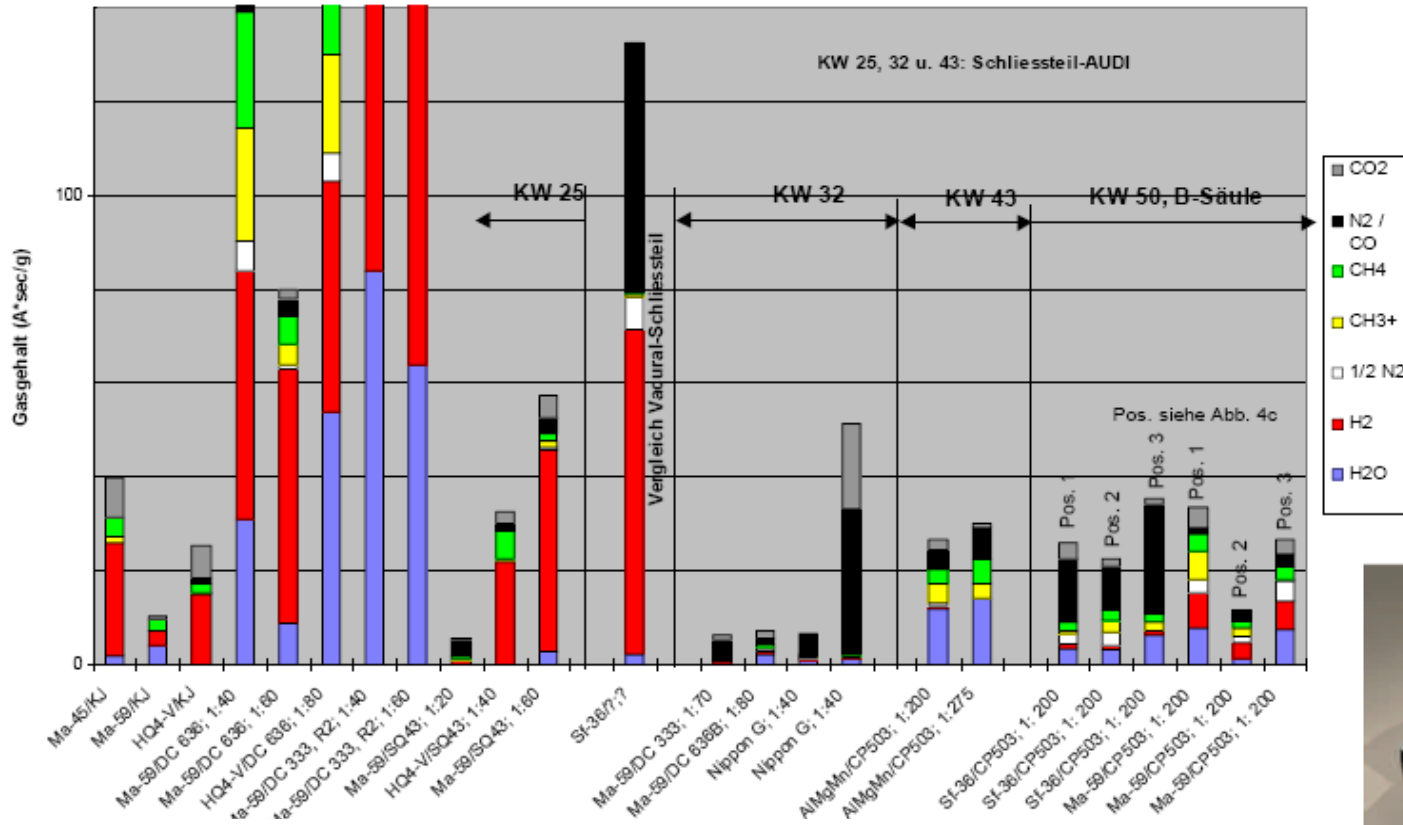

Shot tip with ring to seal cold chamber

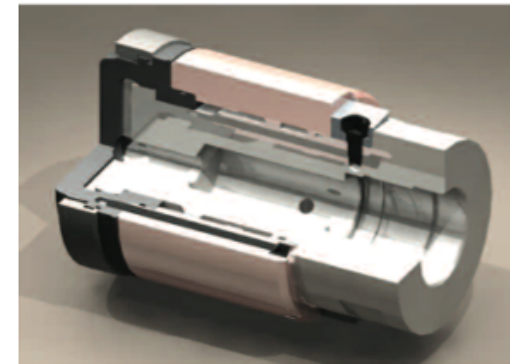

Various Gases Generated from Different Lubricants

# Key to Success: Vacuum

## Why vacuum diecasting:

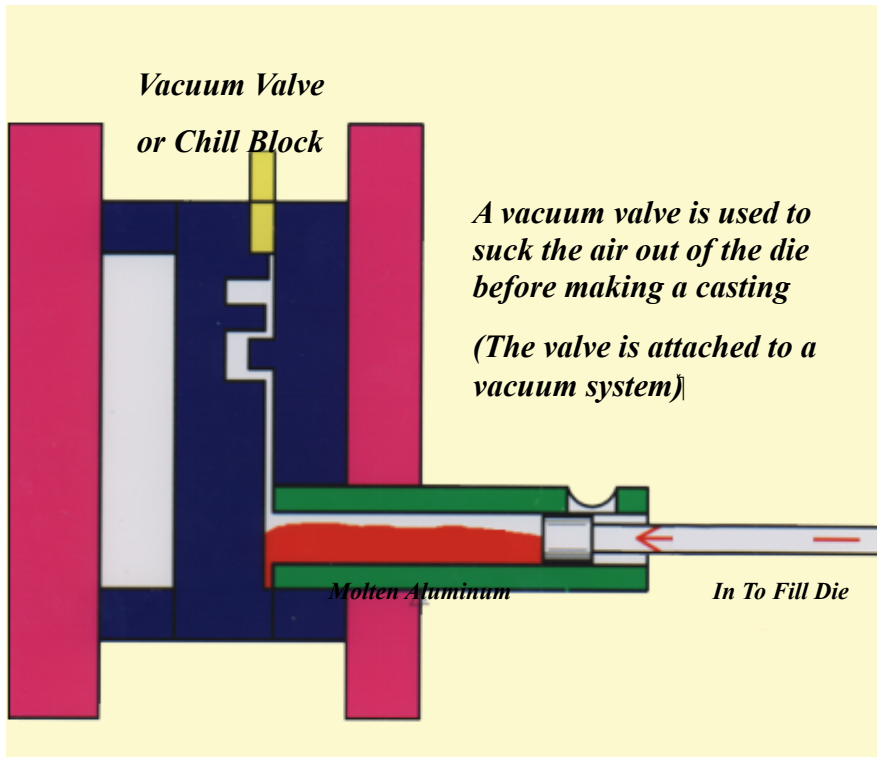

- Vacuum levels in the die cavity 20-300 millibar.
- Reduced cavity gases from the shot sleeve and die.
- Reduced porosity levels
- Reduced scrap
- Reduced wall-thickness
- Reduction of rejected shots
- Reduced scrap after welding or heat treatment
- Ability to produce otherwise unsuitable parts in aluminium die casting

- High vacuum die casting processes should be capable of:*
- Achieving high levels of vacuum (typically < 50 mbar) in the cavity and shot sleeve (ideally 2 stage vacuum) prior to injection and keep them during the shot*
  - Monitoring and control the vacuum level during the casting process*
  - Main differences in equipment/processes are in:*
    - Vacuum valve type*
    - Vacuum control system*
    - Vacuum monitoring approach*

# Key to Success: Vacuum

*Advanced monitoring techniques used to insure proper vacuum level during the casting process, proper vacuum response & vacuum evacuation time and to detect vacuum leaks, vacuum blockages as well as excessive moisture*

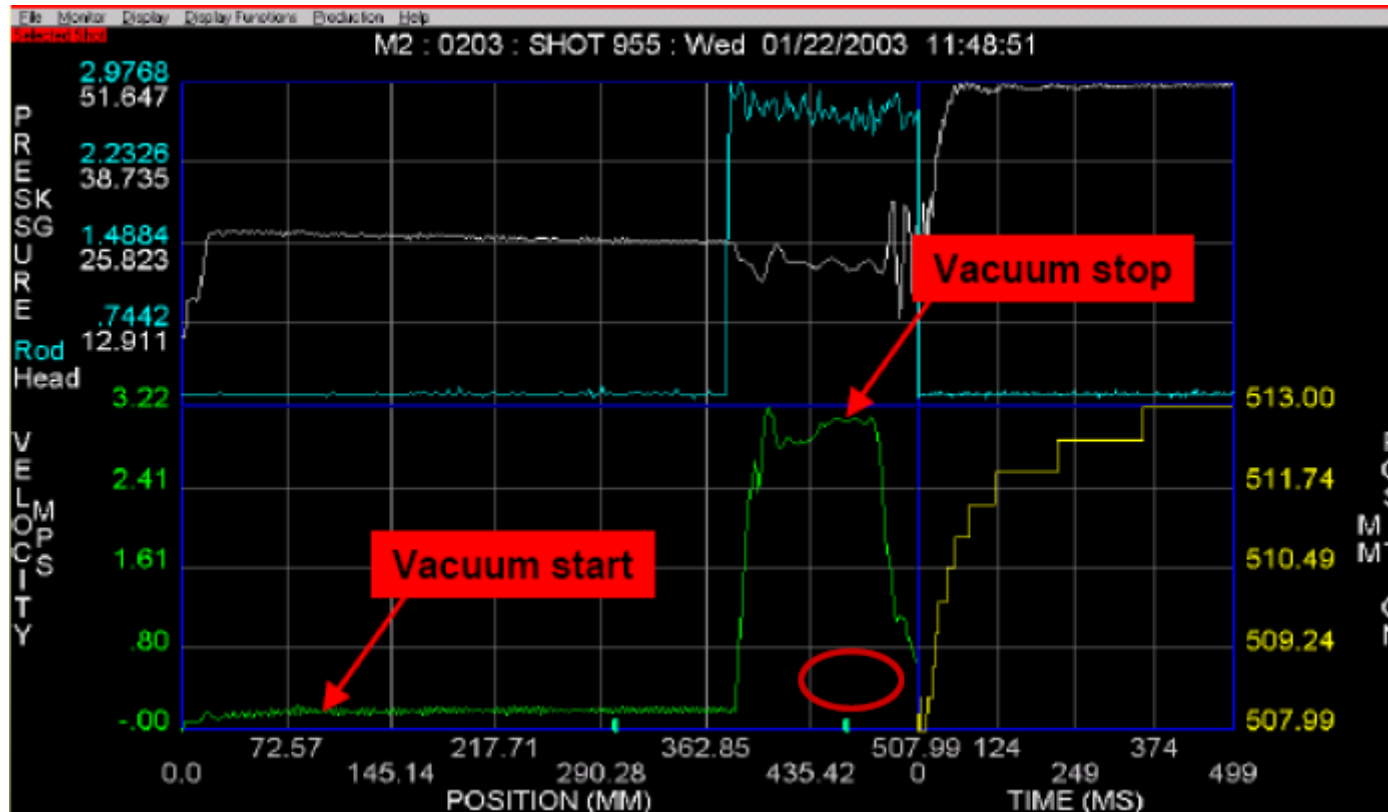



# Key to Success: Vacuum

## Mechanical Valves

### Pros

- Vacuum pulled through entire shot
- Does not require expensive controller
- Easy to remove and clean
- Biscuit size variation is not an issue

### Cons

- *Smaller valve cross sectional area – less vacuum*
- *Potential for metal to fill evacuation line if metal does not completely fill*
- *Valves are expensive*

### Suppliers

- Castool
- Provac/VDS
- Fondarex
- ...

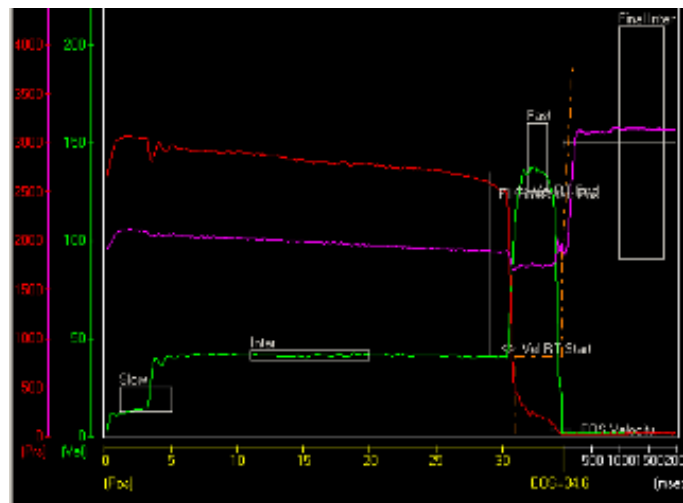

## Hydraulic/ Pneumatic vacuum valves

### Pros

- Allows for larger valve (cross sectional area up to 400 square mm)
- Does not rely on metal to close valve (no issues with startup)
- Usually less down time (no metal shot into valve)

### Cons

- *Requires better control system*
- *drawing vacuum through entire shot is more difficult*
- *Does not account for biscuit variation (requires very stable process)*
- *Requires hydraulic cylinders within tool*

### Suppliers

- MFT
- Buhler/ Prince
- ...

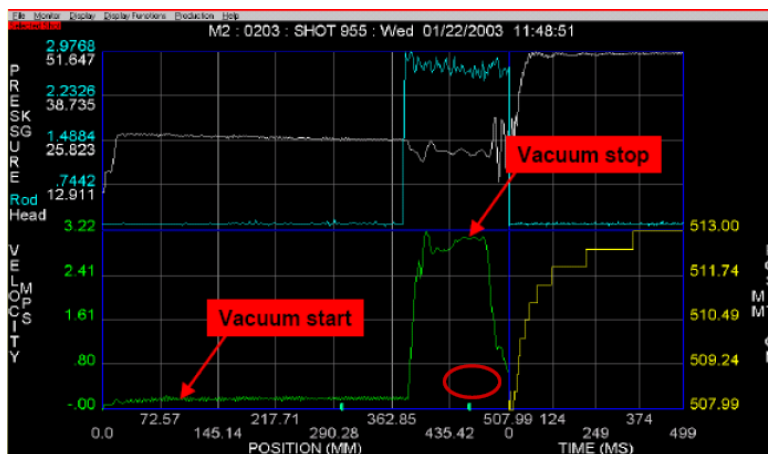

Key to Success: Vacuum

# New chill vent/valve approach **CASTvac**

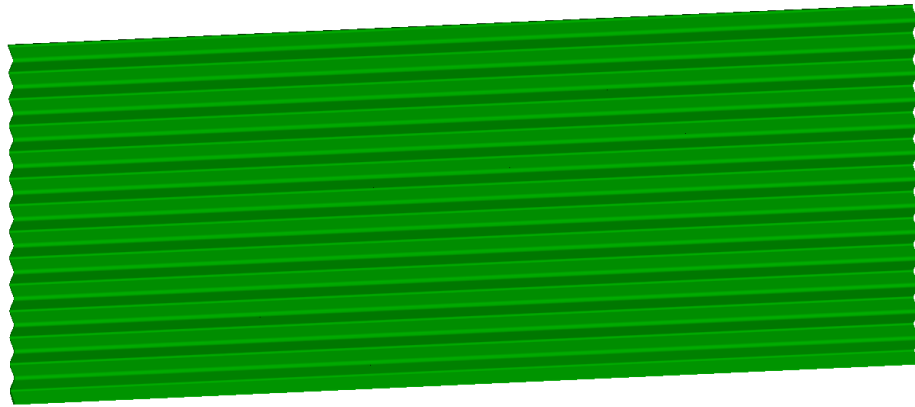

*Chill face: 100mm x 100mm  
requires 80tonne locking force;  
Increased by 4 times: 400mmx100mm  
requires 320tonne locking force*

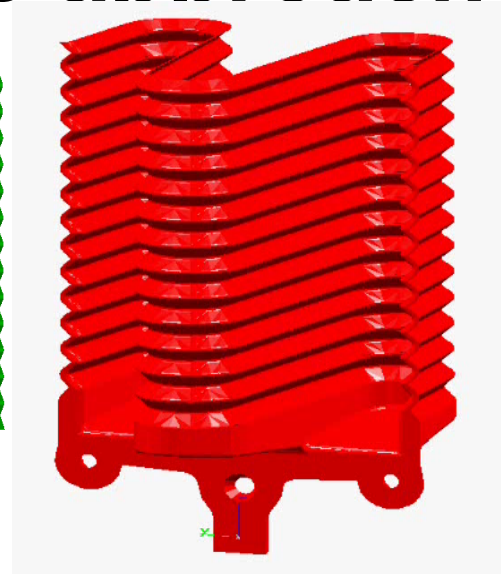

*3D (CASTvac)  
4 times of chill face but  
only 80tonne force*

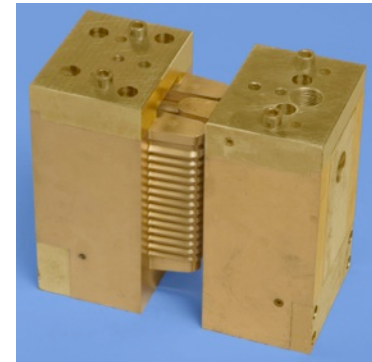
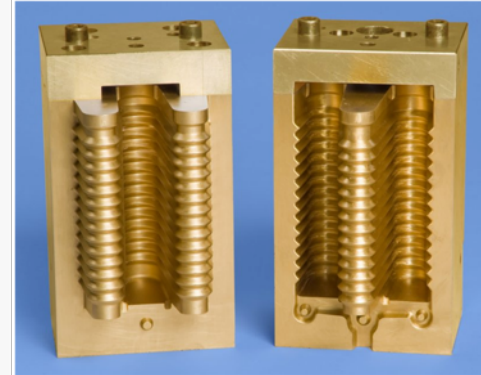

**In production in Nissan Australia for 6 years**

# Key to Success: Vacuum

## Efficiency comparison with bench test

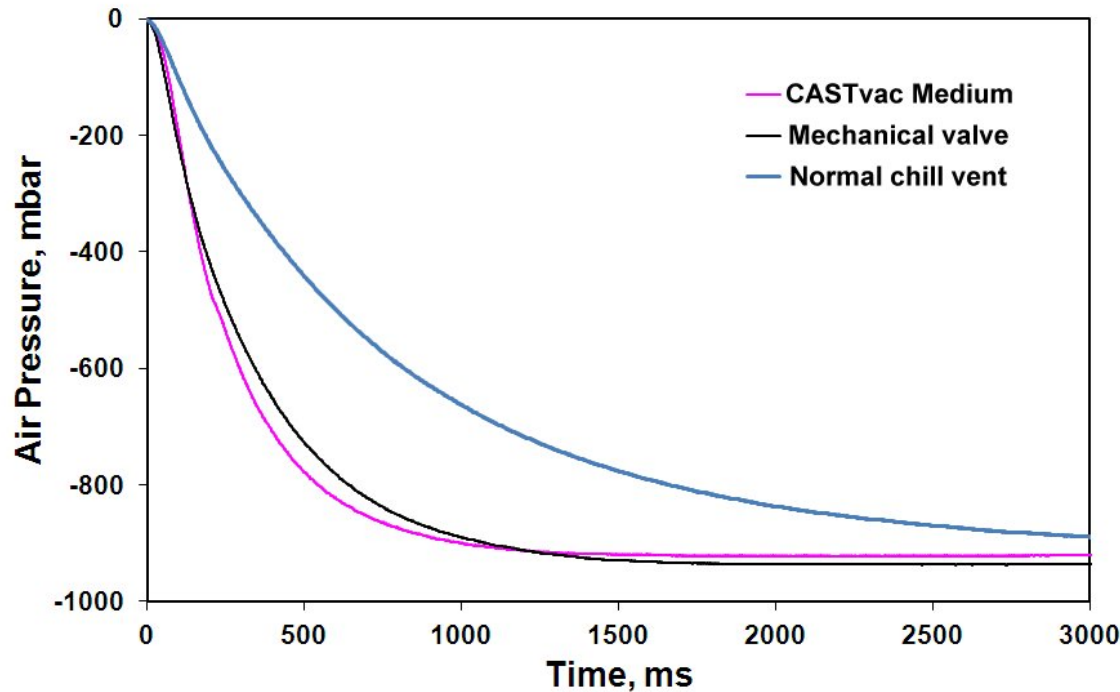

# Key to Success: Vacuum

- *Internal water cooling.*
- *Built-in air blow to self-clean the washboard.*

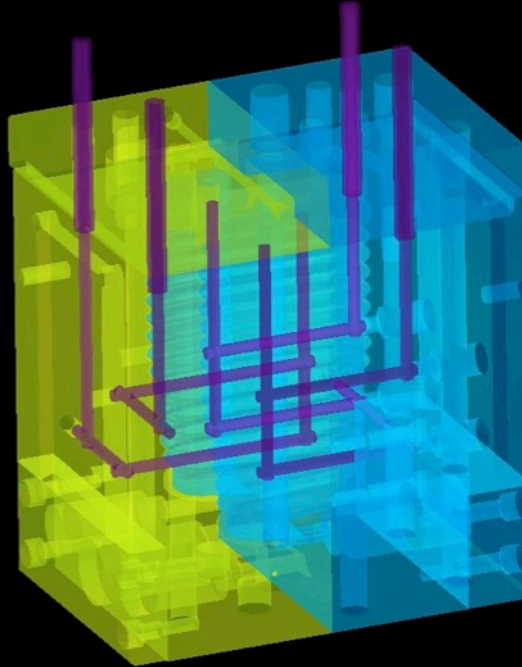

*Built-in spring-loaded ejector pin to enhance the metal ejection; Additional ejection is not required.*

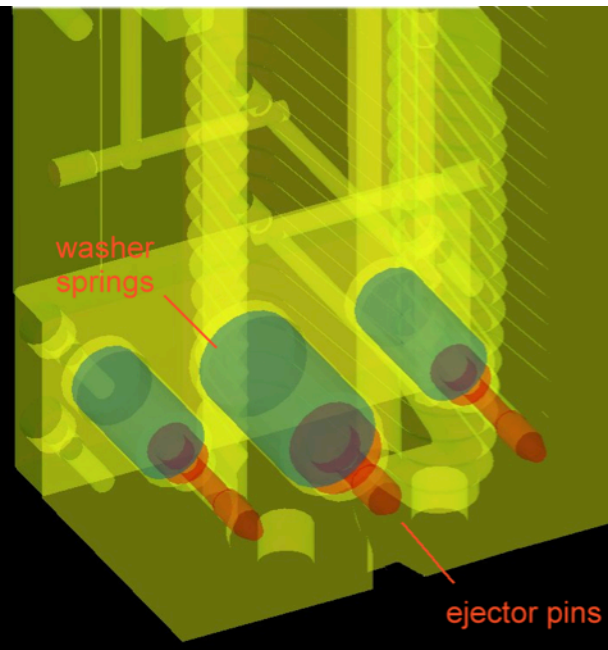
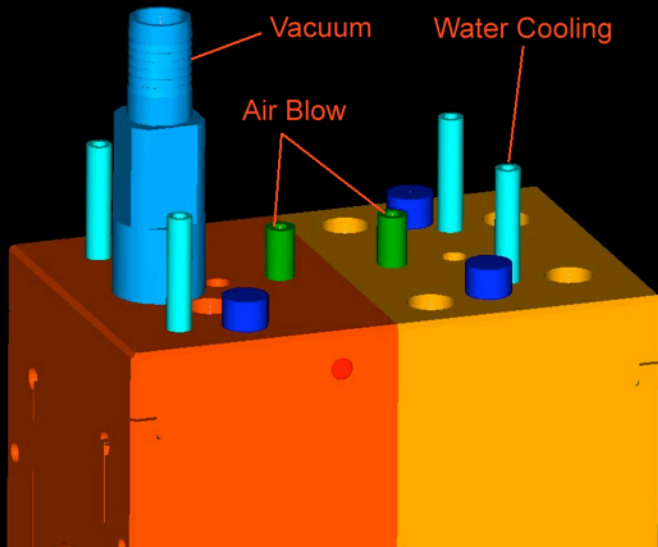

# Key to Success: Vacuum

## Vacuum and moisture are not compatible!

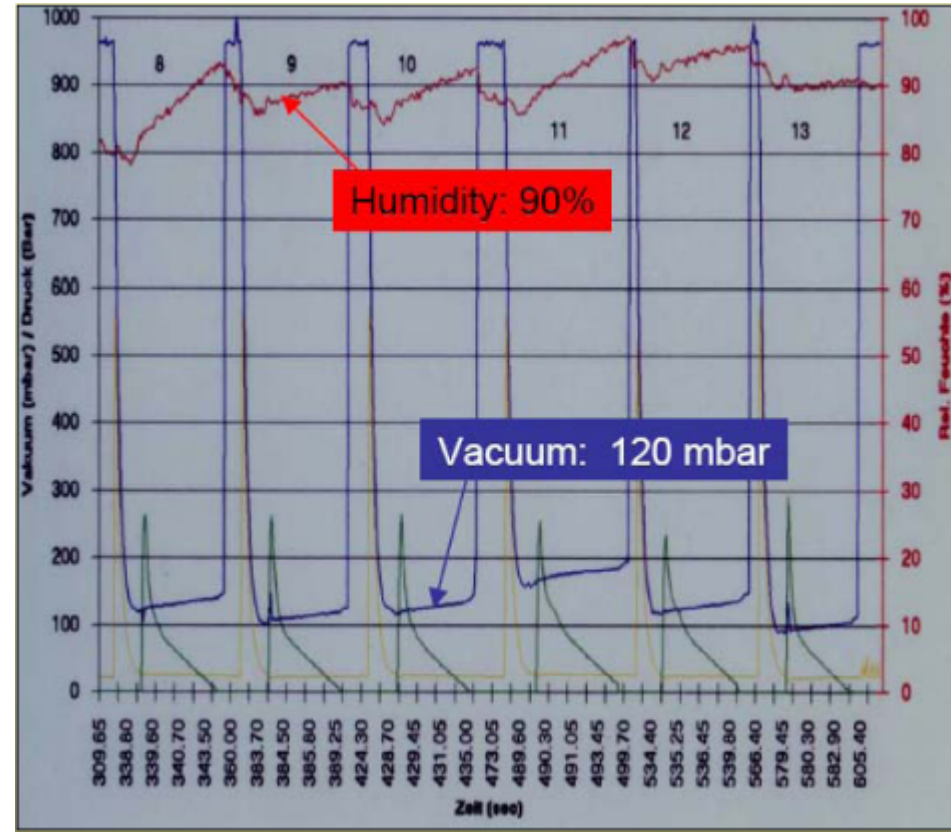
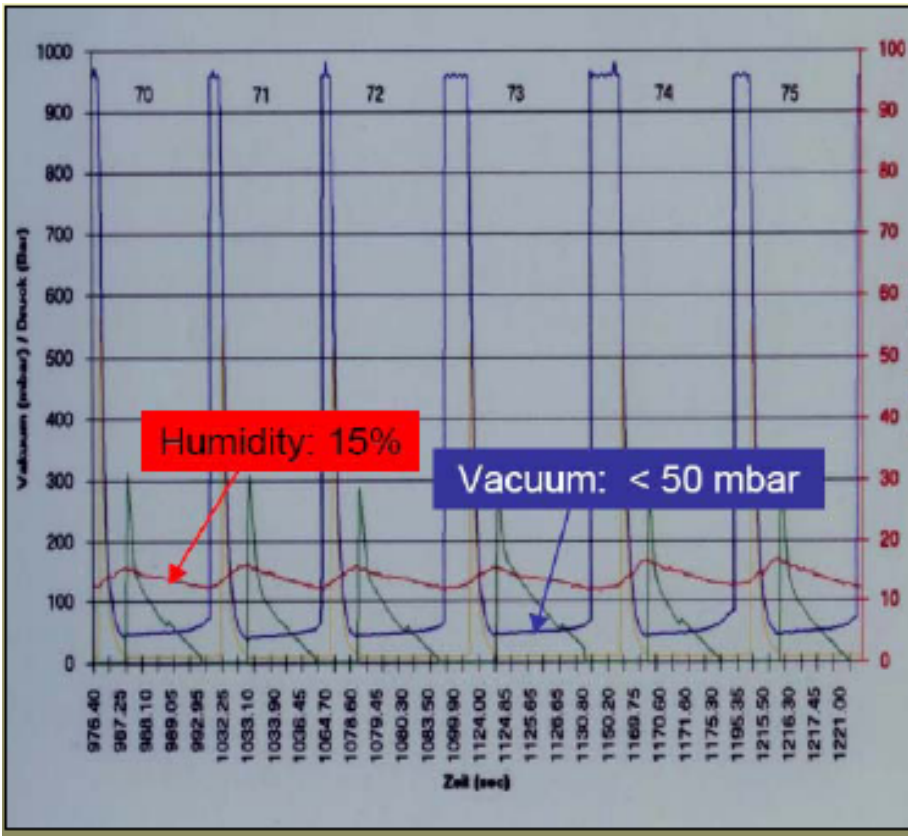

# Key to Success: Traceability

- Proper identification of each part for customer and quality improvement
- Collect, store, archive, recall and download all process information

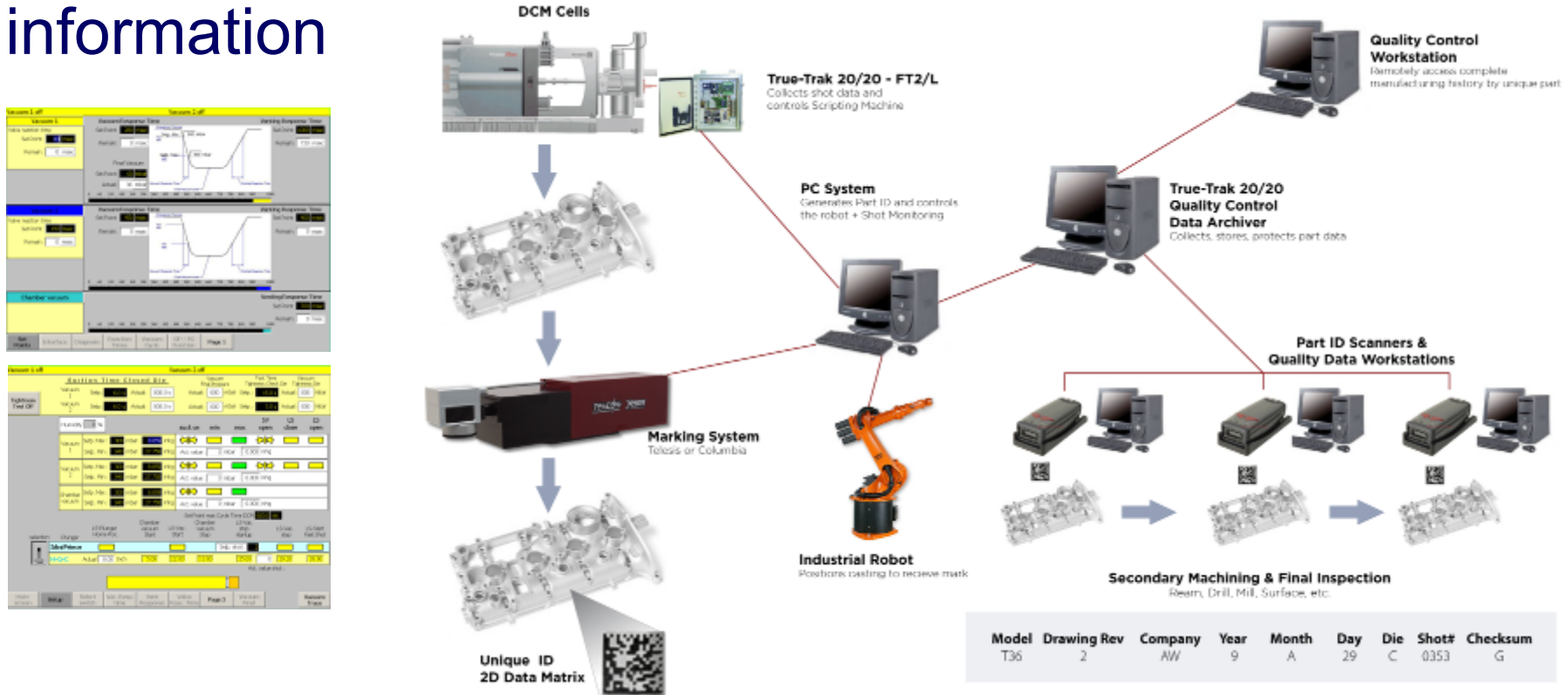

## Network Data Archiver:

- Automatically **collect and archive valuable shot data** for each part (automatic back-up, compress data, store in database)
- **Uniquely identify each part** you produce.
- Capture and **link important secondary process (heat treatment, machining, etc.) and test data.**
- Analyze your data to
  - **Determine cause of variation**
  - **inform your customers and improve quality.**
- **Archive your information** for future access.





# Key to Success: Traceability

**Visi-Trak**<sup>®</sup>  
SENSE, MONITOR, CONTROL



# Plant wide Building Blocks

<b>Plant Mngmt. Solutions</b>	Remote Machine Monitoring
	Quality Control Data Archiving
<b>Advanced DCM Control</b>	Part Scribing & Traceability
	PLC HMI – Visualization, Diagnostic, and Set-up Software
<b>Shot Control</b>	Shot Velocity and Pressure Control Software
	Precision Shot Control Package
	High Performance Valves
<b>Process Monitoring</b>	Data Visualization, Diagnostic, and Shot Monitoring Software
<b>High Speed Data Acquisition</b>	High Speed Data Acquisition System
	Precision Sensor Package

# Outline

- Aluminum content in automotive - The opportunity for diecasters
- Requirements of High Integrity Aluminum HPDC
- Success factors for high integrity HPDC with technological solutions & case studies
- **Alloys and tempers for structural diecastings**
- Products and services for you
- Summary and Q & A

## Alloys for high integrity diecastings

Low Fe (<0.25%), Mn to beat die soldering; low Cu; Sr addition

Al-Si alloy family: Al + 4-12%Si +0-0.6%Mg, Mn, Fe

- Silafont<sup>®</sup>-36 (365), Aural<sup>®</sup>-2/-3 (A365) and -5S, Mercalloy<sup>®</sup> (362, 367, 368), Castasil<sup>®</sup>-37, W3, etc.
- Excellent castability, heat treatable, most commonly used and wide variety of alloys commercially available

Al-Mg-Si family: Al + 2-5.5%Mg + 1.5-3%Si

- Magsimal<sup>®</sup>-59, C446, Aural<sup>®</sup>-11, Calypso 53 & 54SM, etc.
- Excellent properties as cast and in T5 temper
- Difficult to cast, properties extremely wall thickness dependent, require Be, hot tear and SCC susceptible

## Alloys for high integrity diecastings

### The key role of each element:

Si ⇒ higher silicon content alloy promotes fluidity & castability

Mg ⇒ imparts strength

Fe ⇒ helps reduce solder but impacts negatively ductility

Mn ⇒ higher manganese content helps minimize solder and corrects Fe phase

Ti ⇒ used as a grain refiner

Cu ⇒ lower copper content of the alloy imparts higher corrosion resistance (usually strengthening element)

Sr ⇒ helps modify the eutectic silicon, thereby improving ductility of the alloy  
– also helps beat die soldering

# Alloys for high vacuum high integrity HPDC

**Very high Fe:  
An extreme example**

*Al<sub>5</sub>FeSi platelets*

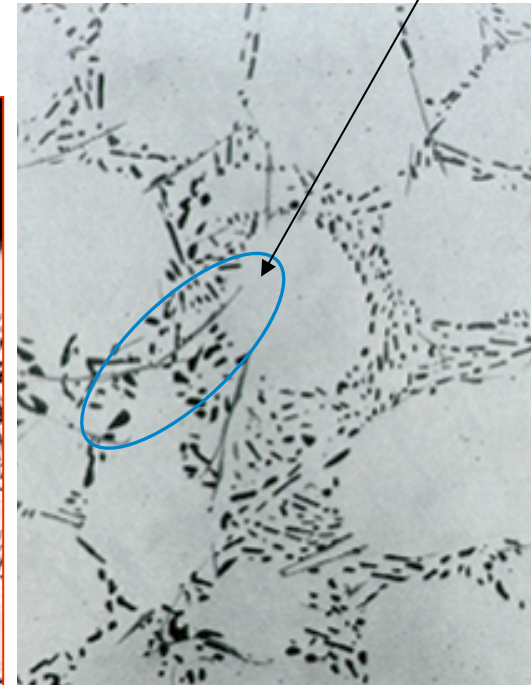

380 alloy (AlSi8Cu3Fe)

# Alloys for high vacuum high integrity HPDC

## Alloys for high integrity diecastings

### The influence of Mn (replacing Fe) mechanical properties (example of Silafont<sup>®</sup> 36)

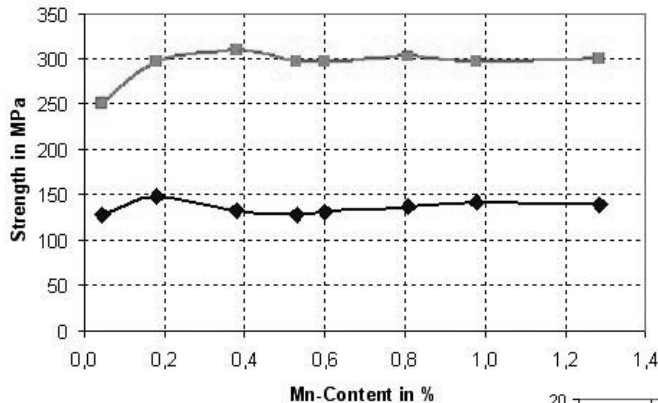

*F temper*

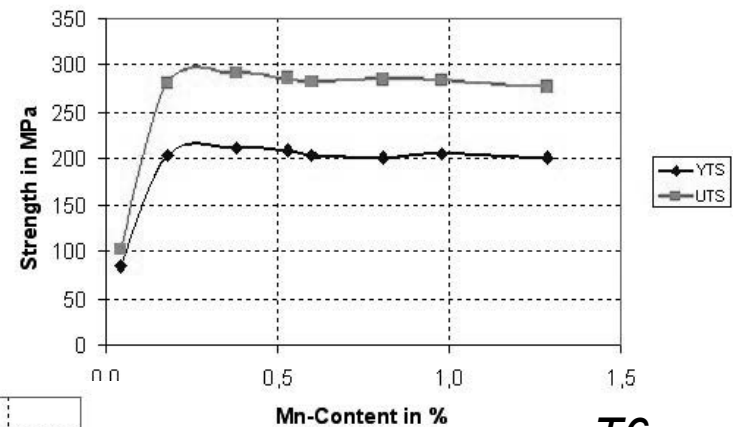

*T6*

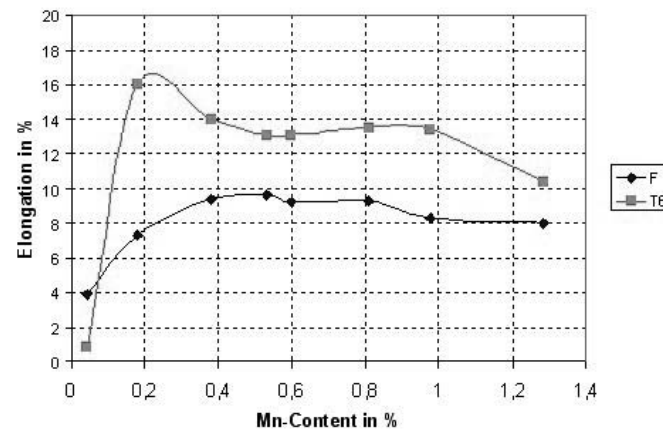

## Alloys for high integrity diecastings

The influence of Si and Mg on mechanical properties in the F temper

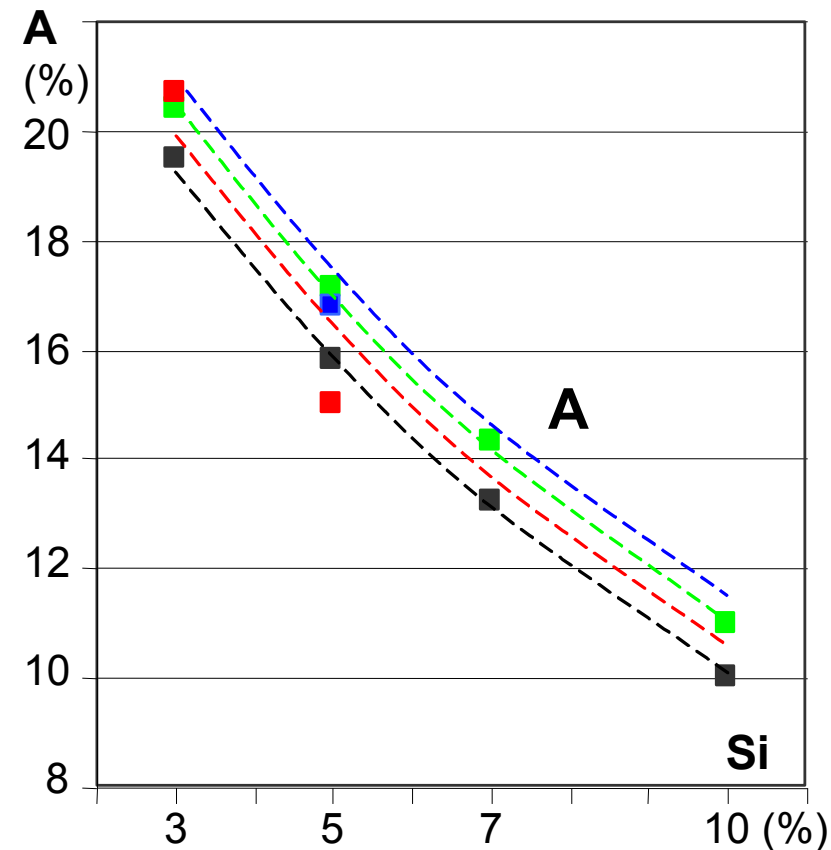
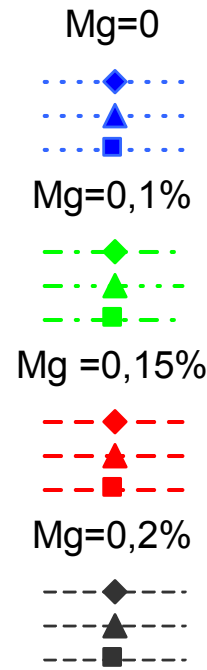
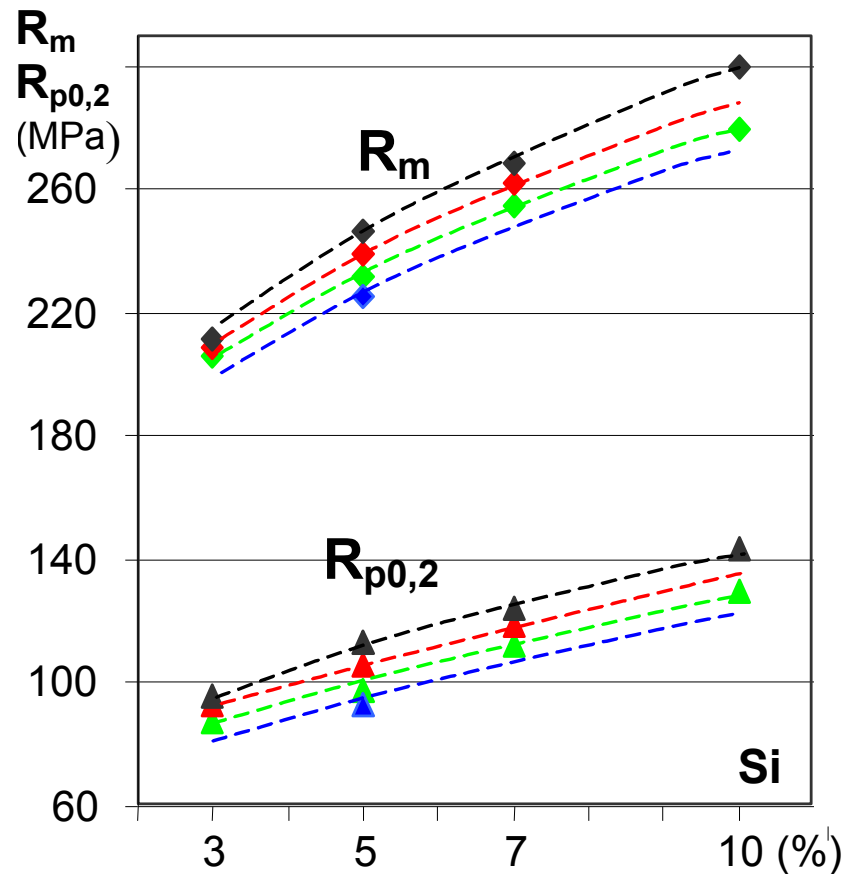



# Alloys for high vacuum high integrity HPDC

## Mericalloy 362

Alloy 362.0											
Alloy 362.0—Chemical Composition Limits											
Si	Fe	Cu	Mn	Mg	Cr	Ni	Zn	Ti	Sr	Other Elements	
										Each	Total
10.5-11.5	0.25	0.20	0.25-0.35	0.50-0.7	--	0.10	0.10	0.20	0.05-0.07	0.05	0.15
Typical Mechanical Properties at 0.60% Mg*											
Casting Process and Temper	Aging Time and Temperature	Tension			Endurance Limit Ksi (Mpa)						
		Ultimate Strength ksi (MPa)	Yield Strength ksi (MPa)	Elongation (%)							
Die Cast 362.0--F	as cast	38-40 (260-275)	18-20 (125-140)	9-11	21 (145)						
Die Cast 362.0--T6	6 hr at 320 F	43-46 (295-315)	33-36 (230-250)	14-16	20 (140)						

\* These properties are for separately cast tensile specimens

# Alloys for high vacuum high integrity HPDC

## Mercalloy 367

Alloy 367.0											
Alloy 367.0—Chemical Composition Limits											
Si	Fe	Cu	Mn	Mg	Cr	Ni	Zn	Ti	Sr	Other Elements	
										Each	Total
8.5-9.5	0.25	0.25	0.25-0.35	0.30-0.50	--	--	0.10	0.20	0.05-0.07	0.05	0.15
Typical Tensile Properties at 0.40% Mg											
Casting Process and Temper		Aging Time and Temperature			Ultimate Strength ksi (MPa)		Yield Strength ksi (MPa)		Elongation (%)		
Die Cast 367.0—F		as cast			39.3 (270)		16.6 (115)		8.1		
Die Cast 367.0—T5		2 hour at 170C			42.8 (295)		24.5 (170)		5.0		
Die Cast 367.0—T5		4 hour at 170C			43.9 (300)		27.8 (190)		6.7		
Die Cast 367.0—T5		6 hour at 170C			45 (310)		29 (200)		8.2		
Die Cast 367.0—T5		8 hour at 170C			45 (310)		30 (205)		9.0		
Die Cast 367.0—T4		3 hr at 490C + water quench			35.6 (245)		21.6 (150)		15		
Die Cast 367.0—T6		2 hour at 170C			43 (295)		33.2 (230)		10.3		
Die Cast 367.0—T6		4 hour at 170C			45 (310)		35 (240)		8		
Die Cast 367.0—T6		6 hour at 170C			43.4 (300)		35.3 (245)		7.8		
Die Cast 367.0—T6		8 hour at 170C			41.4 (285)		33.4 (230)		9.5		

# Alloys for high vacuum high integrity HPDC

## Mericalloy 367

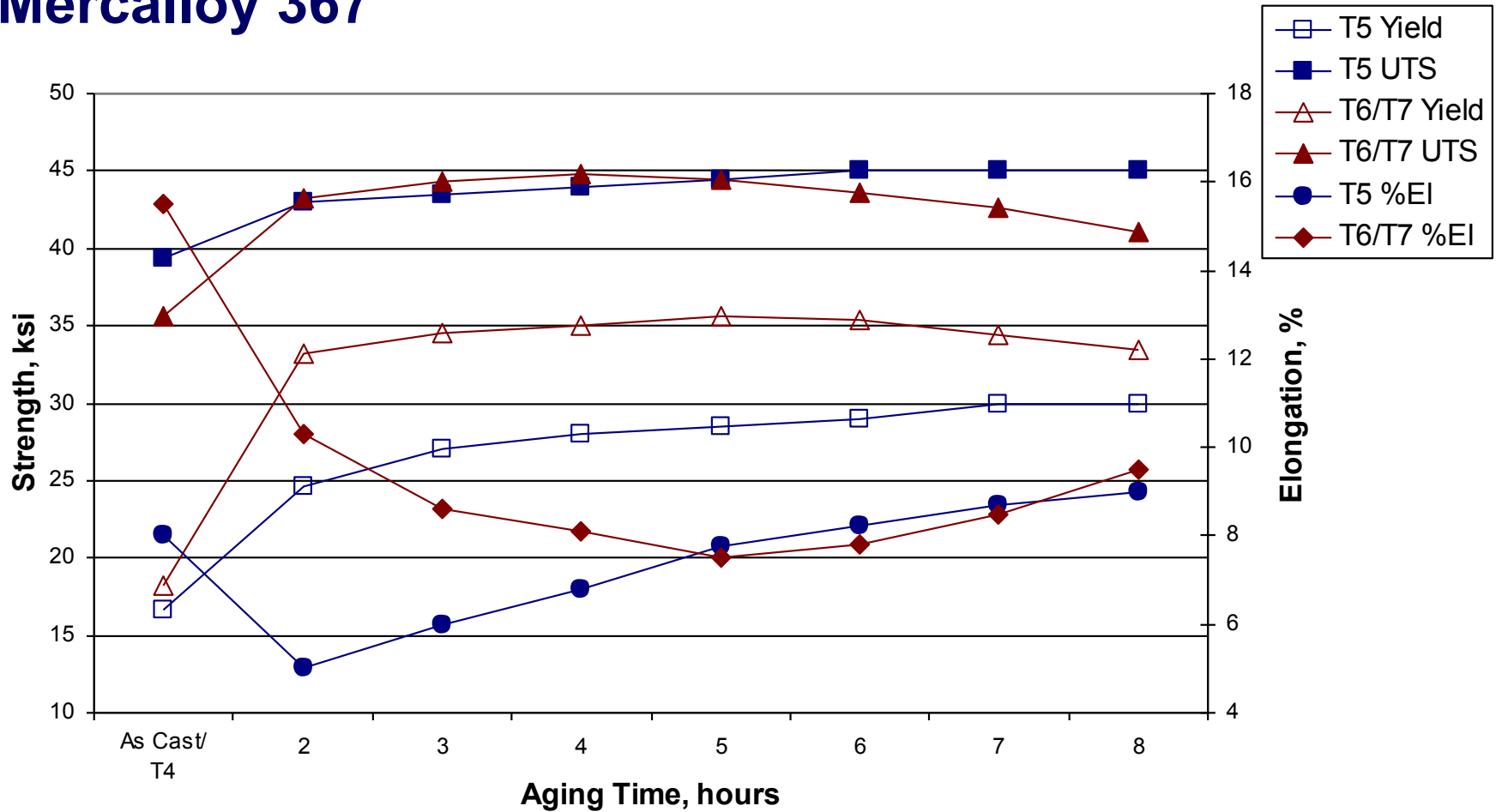

# Alloys for high vacuum high integrity HPDC

## Mercalloy 368

Alloy 368.0											
Alloy 368.0–Chemical Composition Limits											
Si	Fe	Cu	Mn	Mg	Cr	Ni	Zn	Ti	Sr	Other Elements	
										Each	Total
8.5-9.5	0.25	0.25	0.25-0.35	0.10-0.30	--	--	0.10	0.20	0.05-0.07	0.05	0.15
Typical Mechanical Properties at 0.20% Mg*											
Casting Process and Temper	Aging Time and Temperature	Tension			Endurance Limit Ksi (Mpa)						
		Ultimate Strength ksi (MPa)	Yield Strength ksi (MPa)	Elongation (%)							
Die Cast 368.0--F	as cast	38-40 (260-275)	18-20 (125-140)	10-12	21 (145)						
Die Cast 368.0--T6	6 hr at 320 F	41-43 (280-295)	27-29 (185-200)	14-16	20 (140)						

\* These properties are for separately cast tensile specimens

# Alloys for high vacuum high integrity HPDC

## Alloys for high integrity diecastings

Example: CALYPSO 61D (Al Si10MgMnFe) :  
Difference between crash behaviors in T7 and F

Courbe de crash dynamique

Force vs time curves, *T7* and *F* conditions

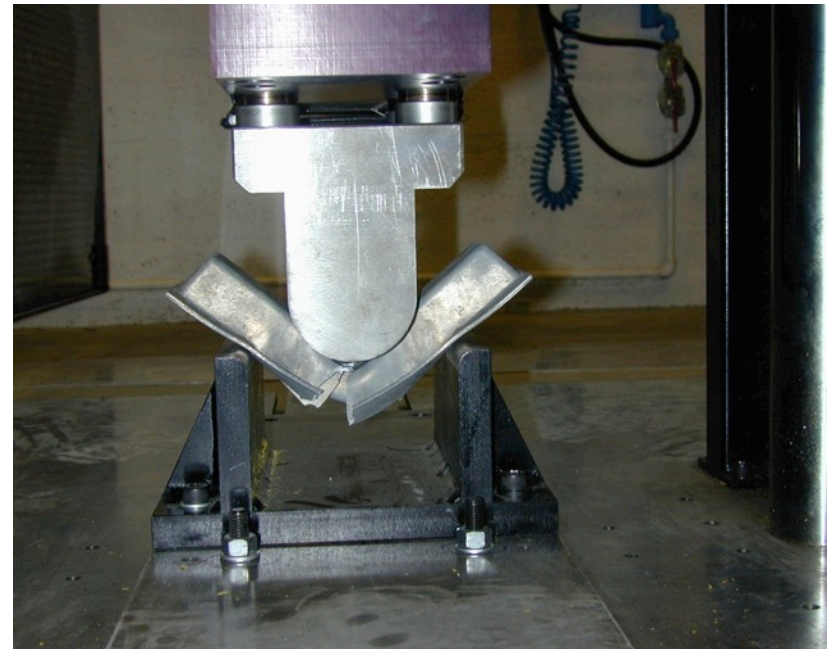
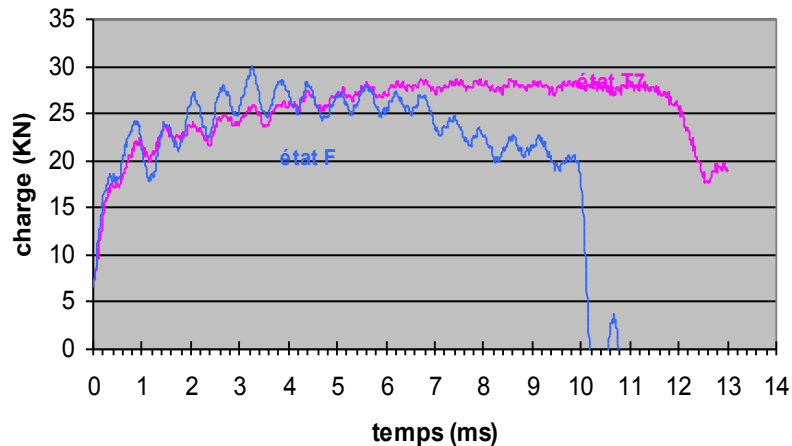

**Condition**

**F**

**T7**

**YS**

**120 ~ 140**

**155 ~ 165**

**UTS**

**270 ~ 290**

**215 ~ 225**

**Elongation %**

**10 ~ 12**

**14 ~ 18**

# Alloys for high vacuum high integrity HPDC

## Alloys for high integrity diecastings

Example: CALYPSO 61D (Al Si10MgMnFe) :  
Difference between crash behaviors in T7 and F



**T7**



**F**

# Alloys for high vacuum high integrity HPDC

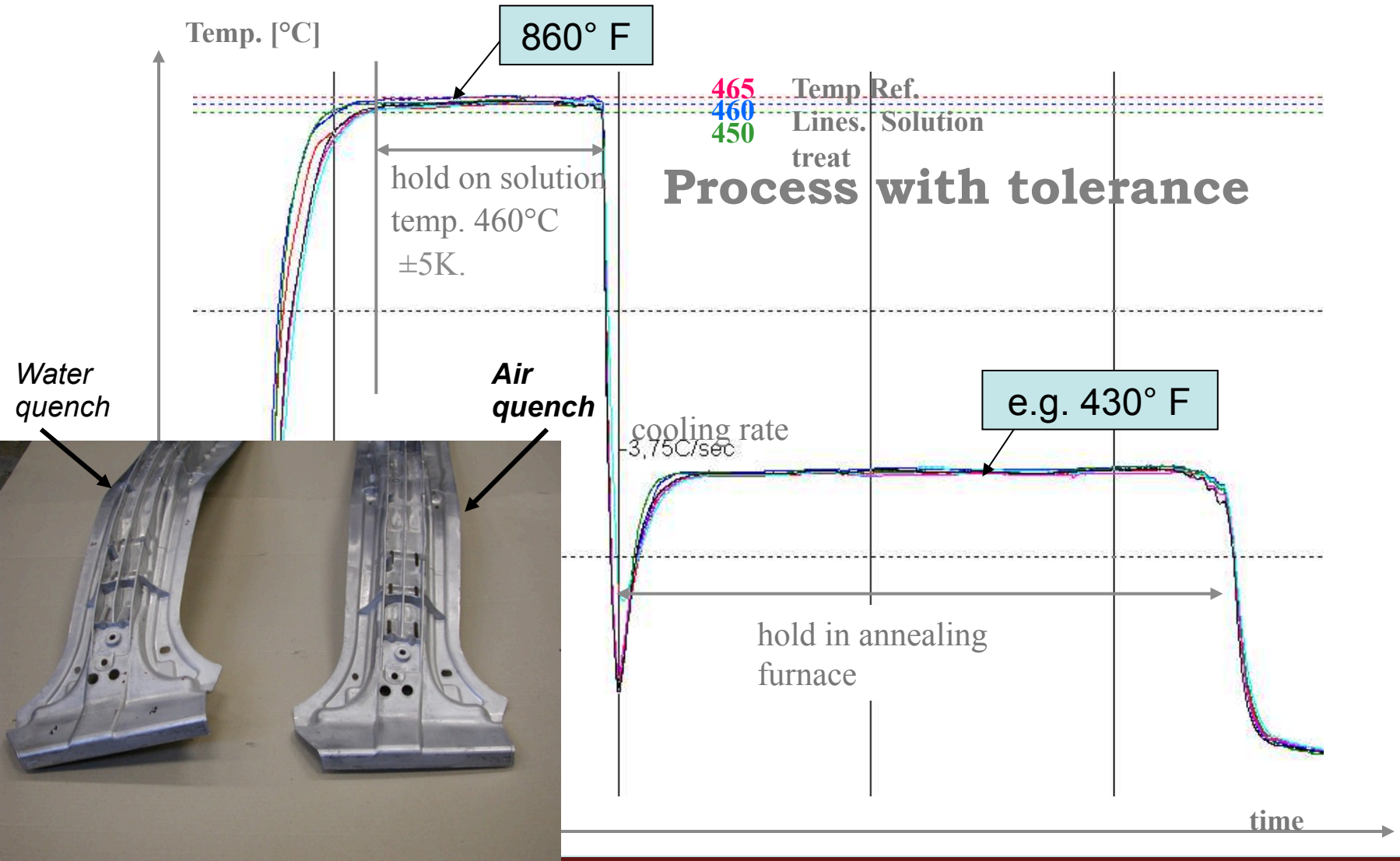

## Outline

- Aluminum content in automotive - The opportunity for diecasters
- Requirements of High Integrity Aluminum HPDC
- Success factors for high integrity HPDC with technological solutions & case studies
- Alloys and tempers for structural diecastings
- **Products and services for you**
- Summary and Q & A



## Products offered

- Per Die-casting Machine
  - Process Monitoring
  - Process Control
  - Thermal monitoring of die
  - Metal Treatment Specifications
  - Alloy and Heat Treatment specification
  - Production Start-up Support
  - Additional Support on Demand

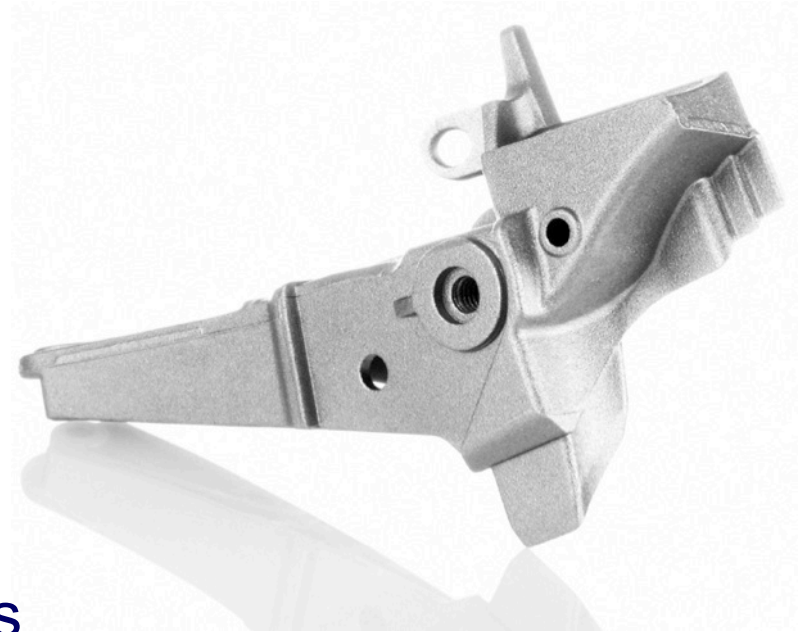

## Services offered

- Alloy and process selection, optimization and sourcing
  - Chemical composition of alloy (specification)
  - Guidelines for melting, melt treatment, melt transfer, etc.
  - Diecasting process improvement/optimization
- Casting simulation and optimization
- Heat Treatment for minimized distortion
- Guidelines (Temperatures, Times, quenching, etc.)
- Engineering Support
  - DCM-Set-up, HT-Process, Melting,...
  - Project Management
- Training for engineers, operators, managers, ...



# Outline

- Aluminum content in automotive - The opportunity for diecasters
- Requirements of High Integrity Aluminum HPDC
- Success factors for high integrity HPDC with technological solutions & case studies
- Alloys and tempers for structural diecastings
- Products and services for you
- **Summary and Q & A**

# Summary

- Traditional diecasting processes had difficulty in achieving high integrity (low porosity) castings and were therefore unusable for structural applications
- Traditional diecasting has relied upon high levels of Fe in Al to reduce die soldering. As known, Fe also destroys mechanical properties (especially elongation)
- New diecasting processes applying process control, vacuum, proper die design, etc. and new alloys allow production of castings with high quality / mechanical properties (heat treatable, weldable, crash worthy, etc.)
- The inherent advantages of diecasting (high freezing rate, thin walls, high precision, etc.) can now be used to produce high quality structural castings at competitive costs

**Jack Vann**  
**President**

Visi-Trak Worldwide  
8400 Sweet Valley Drive, Suite 406  
Valley View, OH 44125-4244  
USA

**Office Phone:** 800-252-8725

[jvann@visi-trak.com](mailto:jvann@visi-trak.com)

[www.Visi-Trak.com](http://www.Visi-Trak.com)

**Martin Hartlieb**

Viami International, Inc.  
267 Rue Alice Carriere  
Beaconsfield, QC, H9W 6E6  
Canada

**Office Phone:** +1 514 426 1814

[martin.hartlieb@viami.ca](mailto:martin.hartlieb@viami.ca)

[www.viami.ca](http://www.viami.ca)

*Thank You*

